

Series AD-31 and Series L4 Extrusion Handguns

Customer Product Manual

Part 107105C04

Issued 5/05



NORDSON CORPORATION • DULUTH, GEORGIA • USA
www.nordson.com

For CE Declaration, refer to melter documentation.

Nordson Corporation welcomes requests for information, comments, and inquiries about its products. General information about Nordson can be found on the Internet using the following address: <http://www.nordson.com>.

Address all correspondence to:

Nordson Corporation
Attn: Customer Service
11475 Lakefield Drive
Duluth, GA 30097

Notice

This is a Nordson Corporation publication which is protected by copyright. Original copyright date 1995. No part of this document may be photocopied, reproduced, or translated to another language without the prior written consent of Nordson Corporation. The information contained in this publication is subject to change without notice.

Trademarks

AccuJet, AeroCharge, Apogee, AquaGuard, Asymtek, Automove, Baitgun, Blue Box, CanWorks, Century, CF, Clean Coat, CleanSleeve, CleanSpray, ColorMax, Control Coat, Coolwave, Cross-Cut, Cyclo-Kinetic, Dispensejet, DispenseMate, DuraBlue, Durafiber, Dura-Screen, Durasystem, Easy Coat, Easymove Plus, EcoDry, Econo-Coat, e.dot, EFD, ETI, Excel 2000, Fillmaster, FlexiCoat, Flexi-Spray, Flex-O-Coat, Flow Sentry, Fluidmove, FoamMelt, FoamMix, Heli-flow, Helix, Horizon, Hot Shot, iControl, Isocoil, Isocore, Iso-Flo, Kinetix, Little Squirt, Magnastatic, March, MEG, Meltex, Microcoat, Micromark, MicroSet, Millennium, Mini Squirt, Mountaingate, MultiScan, Nordson, OptiMix, Package of Values, Pattern View, PermaFlo, Plasmod, Porous Coat, PowderGrid, Powderware, Printplus, Prism, ProBlue, Pro-Flo, ProLink, Pro-Meter, Pro-Stream, RBX, Rhino, Saturn, Scoreguard, Seal Sentry, Select Charge, Select Coat, Select Cure, Slautterback, Smart-Coat, Solder Plus, Spectrum, Speed-Coat, SureBead, Sure Coat, Sure-Max, Tracking Plus, Trends, Tribomatic, Ultrasaver, UpTime, Veritec, VersaBlue, Versa-Coat, Versa-Screen, Versa-Spray, Walcom, Watermark, and When you expect more are registered trademarks of Nordson Corporation.

Accubar, Advanced Plasma Systems, AeroDeck, AeroWash, AquaCure, ATS, Auto-Flo, AutoScan, Check Mate, Controlled Fiberization, Control Weave, CPX, DispensLink, Dry Cure, DuraBraid, DuraCoat, DuraDrum, DuraPail, Easy Clean, Eclipse, E-Nordson, Equi=Bead, ESP, e.Stylized, Fill Sentry, HDLV, iFlow, iON, Iso-Flex, iTrend, iTRAX, Lacquer Cure, Lean Cell, Maverick, Maxima, MicroFin, MicroMax, Minimeter, Multifil, OptiStroke, PatternPro, PCI, Powder Pilot, Powercure, Primarc, Process Sentry, Prodigy, Pulse Spray, QuadCure, Ready Coat, Royal Blue, Select Series, Sensomatic, Shaftshield, SheetAire, Smart, Spectral, Spectronic, Speedking, Spray Works, Summit, Sure Brand, Sure Clean, Sure Wrap, Swirl Coat, Tempus, ThruWave, Trade Plus, Trak, TrueBlue, Ultra, Ultrasmart, Universal, Vantage, Vista, Web Cure, and 2 Rings (Design) are trademarks of Nordson Corporation.

Designations and trademarks stated in this document may be brands that, when used by third parties for their own purposes, could lead to violation of the owners' rights.

Table of Contents

Safety	1
Safety Alert Symbols	1
Equipment Safety Information	2
Equipment Shutdown	2
General Safety Warnings and Cautions	3
Other Safety Precautions	6
First Aid	6
Description	7
Standard Features	8
Optional Features	8
Specifications	8
Handgun Selection	10
Installation	11
Hose/Gun Connection	12
Connect the Hose	12
Electrical Connections	14
Connections for Specific Handgun Configurations	14
Configuration A: RTD-Style AD-31, Series 5000	14
Configuration B: AD-31 RTD Style Other than Series 5000	16
Configuration C: Thermostat Style AD-31	18
Configuration D: RTD-style L4	20
Configuration E: Thermostat-style L4	22
Operation	23
Startup	24
Operation	24
Shutdown	25
Maintenance	25
Daily Maintenance	26
Weekly Maintenance	26
Required Items	26
Nozzle Cleaning	26
Semiannual Maintenance	28
Troubleshooting	29
Troubleshooting Table	29

Repair	32
Replace the RTD	33
Replace the Thermostat	34
Replace the Heater Cartridge	35
Replace the Swivel Bearing	37
Remove the Swivel Bearing	38
Reinstall the Swivel Bearing	38
Replace the Packing Cartridge	41
Adjust the Trigger	43
Adjust the Trigger Electrical Switch	44
Replace an Existing Gun	45
Remove the Existing Handgun	45
Install the New Handgun	46
Check for Leaks	48
Using the Illustrated Parts Lists	49
Handgun Parts Lists	50
AD-31 Model K Handgun Parts	50
AD-31 Models B and C Handgun Parts	54
AD-31 Models A, T and TL Handgun Parts	58
AD-31 Models D, L, E and P Handgun Parts	62
L4 Handgun Parts	66
Recommended Spare Parts	69
AD-31 Handgun Spare Parts List	69
L4 Handgun Spare Parts List	70
Extrusion Nozzles	71
Male-Threaded Standard Engagement Nozzles, Small Ball-and-Seat	71
Male-Threaded Extended Engagement Nozzles, Small Ball-and-Seat	71
Male-Threaded Extended Engagement Nozzles, Large Ball-and-Seat	72
Accessories	72

AD-31 Hand Guns

Safety

Read this section before using the equipment. This section contains recommendations and practices applicable to the safe installation, operation, and maintenance (hereafter referred to as “use”) of the product described in this document (hereafter referred to as “equipment”). Additional safety information, in the form of task-specific safety alert messages, appears as appropriate throughout this document.



WARNING: Failure to follow the safety messages, recommendations, and hazard avoidance procedures provided in this document can result in personal injury, including death, or damage to equipment or property.

Safety Alert Symbols

The following safety alert symbol and signal words are used throughout this document to alert the reader to personal safety hazards or to identify conditions that may result in damage to equipment or property. Comply with all safety information that follows the signal word.



WARNING: Indicates a potentially hazardous situation that, if not avoided, can result in serious personal injury, including death.



CAUTION: Indicates a potentially hazardous situation that, if not avoided, can result in minor or moderate personal injury.

CAUTION: (Used without the safety alert symbol) Indicates a potentially hazardous situation that, if not avoided, can result in damage to equipment or property.

Equipment Safety Information

This equipment safety information is applicable to the following types of Nordson equipment:

- hot melt and cold adhesive application equipment and all related accessories
- pattern controllers, timers, detection and verification systems, and all other optional process control devices

Equipment Shutdown

To safely complete many of the procedures described in this document, the equipment must first be shut down. The level of shut down required varies by the type of equipment in use and the procedure being completed. If required, shut down instructions are specified at the start of the procedure. The levels of shut down are:

Relieving System Hydraulic Pressure

Completely relieve system hydraulic pressure before breaking any hydraulic connection or seal. Refer to the melter-specific product manual for instructions on relieving system hydraulic pressure.

De-energizing the System

Isolate the system (melter, hoses, guns, and optional devices) from all power sources before accessing any unprotected high-voltage wiring or connection point.

1. Turn off the equipment and all auxiliary devices connected to the equipment (system).
2. To prevent the equipment from being accidentally energized, lock and tag the disconnect switch(es) or circuit breaker(s) that provide input electrical power to the equipment and optional devices.

NOTE: Government regulations and industry standards dictate specific requirements for the isolation of hazardous energy sources. Refer to the appropriate regulation or standard.

Disabling the Guns

All electrical or mechanical devices that provide an activation signal to the guns, gun solenoid valve(s), or the melter pump must be disabled before work can be performed on or around a gun that is connected to a pressurized system.

1. Turn off or disconnect the gun triggering device (pattern controller, timer, PLC, etc.).
2. Disconnect the input signal wiring to the gun solenoid valve(s).
3. Reduce the air pressure to the gun solenoid valve(s) to zero; then relieve the residual air pressure between the regulator and the gun.

General Safety Warnings and Cautions

Table 1 contains the general safety warnings and cautions that apply to Nordson hot melt and cold adhesive equipment. Review the table and carefully read all of the warnings or cautions that apply to the type of equipment described in this manual.

Equipment types are designated in Table 1 as follows:







HM = Hot melt (melters, hoses, guns, etc.)

PC = Process control

CA = Cold adhesive (dispensing pumps, pressurized container, and guns)



General Safety Warnings and Cautions (contd)

Table 1 General Safety Warnings and Cautions

Equipment Type	Warning or Caution
HM	 <p>WARNING: Hazardous vapors! Before processing any polyurethane reactive (PUR) hot melt or solvent-based material through a compatible Nordson melter, read and comply with the material's MSDS. Ensure that the material's processing temperature and flashpoints will not be exceeded and that all requirements for safe handling, ventilation, first aid, and personal protective equipment are met. Failure to comply with MSDS requirements can cause personal injury, including death.</p>
HM	 <p>WARNING: Reactive material! Never clean any aluminum component or flush Nordson equipment with halogenated hydrocarbon fluids. Nordson melters and guns contain aluminum components that may react violently with halogenated hydrocarbons. The use of halogenated hydrocarbon compounds in Nordson equipment can cause personal injury, including death.</p>
HM, CA	 <p>WARNING: System pressurized! Relieve system hydraulic pressure before breaking any hydraulic connection or seal. Failure to relieve the system hydraulic pressure can result in the uncontrolled release of hot melt or cold adhesive, causing personal injury.</p>
HM	 <p>WARNING: Molten material! Wear eye or face protection, clothing that protects exposed skin, and heat-protective gloves when servicing equipment that contains molten hot melt. Even when solidified, hot melt can still cause burns. Failure to wear appropriate personal protective equipment can result in personal injury.</p>
HM, PC	 <p>WARNING: Equipment starts automatically! Remote triggering devices are used to control automatic hot melt guns. Before working on or near an operating gun, disable the gun's triggering device and remove the air supply to the gun's solenoid valve(s). Failure to disable the gun's triggering device and remove the supply of air to the solenoid valve(s) can result in personal injury.</p>
HM, CA, PC	 <p>WARNING: Risk of electrocution! Even when switched off and electrically isolated at the disconnect switch or circuit breaker, the equipment may still be connected to energized auxiliary devices. De-energize and electrically isolate all auxiliary devices before servicing the equipment. Failure to properly isolate electrical power to auxiliary equipment before servicing the equipment can result in personal injury, including death.</p>

Continued...

Table 1 General Safety Warnings and Cautions (contd)

Equipment Type	Warning or Caution
HM, CA, PC	 <p>WARNING: Risk of fire or explosion! Nordson adhesive equipment is not rated for use in explosive environments and should not be used with solvent-based adhesives that can create an explosive atmosphere when processed. Refer to the MSDS for the adhesive to determine its processing characteristics and limitations. The use of incompatible solvent-based adhesives or the improper processing of solvent-based adhesives can result in personal injury, including death.</p>
HM, CA, PC	 <p>WARNING: Allow only personnel with appropriate training and experience to operate or service the equipment. The use of untrained or inexperienced personnel to operate or service the equipment can result in injury, including death, to themselves and others and can damage to the equipment.</p>
HM	 <p>CAUTION: Hot surfaces! Avoid contact with the hot metal surfaces of guns, hoses, and certain components of the melter. If contact can not be avoided, wear heat-protective gloves and clothing when working around heated equipment. Failure to avoid contact with hot metal surfaces can result in personal injury.</p>
HM	<p>CAUTION: Some Nordson melters are specifically designed to process polyurethane reactive (PUR) hot melt. Attempting to process PUR in equipment not specifically designed for this purpose can damage the equipment and cause premature reaction of the hot melt. If you are unsure of the equipment's ability to process PUR, contact your Nordson representative for assistance.</p>
HM, CA	<p>CAUTION: Before using any cleaning or flushing compound on or in the equipment, read and comply with the manufacturer's instructions and the MSDS supplied with the compound. Some cleaning compounds can react unpredictably with hot melt or cold adhesive, resulting in damage to the equipment.</p>
HM	<p>CAUTION: Nordson hot melt equipment is factory tested with Nordson Type R fluid that contains polyester adipate plasticizer. Certain hot melt materials can react with Type R fluid and form a solid gum that can clog the equipment. Before using the equipment, confirm that the hot melt is compatible with Type R fluid.</p>

Other Safety Precautions

- Do not use an open flame to heat hot melt system components.
- Check high pressure hoses daily for signs of excessive wear, damage, or leaks.
- Never point a dispensing handgun at yourself or others.
- Suspend dispensing handguns by their proper suspension point.

First Aid

If molten hot melt comes in contact with your skin:

1. Do NOT attempt to remove the molten hot melt from your skin.
2. Immediately soak the affected area in clean, cold water until the hot melt has cooled.
3. Do NOT attempt to remove the solidified hot melt from your skin.
4. In case of severe burns, treat for shock.
5. Seek expert medical attention immediately. Give the MSDS for the hot melt to the medical personnel providing treatment.

Description

Series AD-31 and Series L4 extrusion handguns feature an ever-cool handle with no heated components or adhesive-flow paths. Heated gun components are completely enclosed within the exterior gun shell.

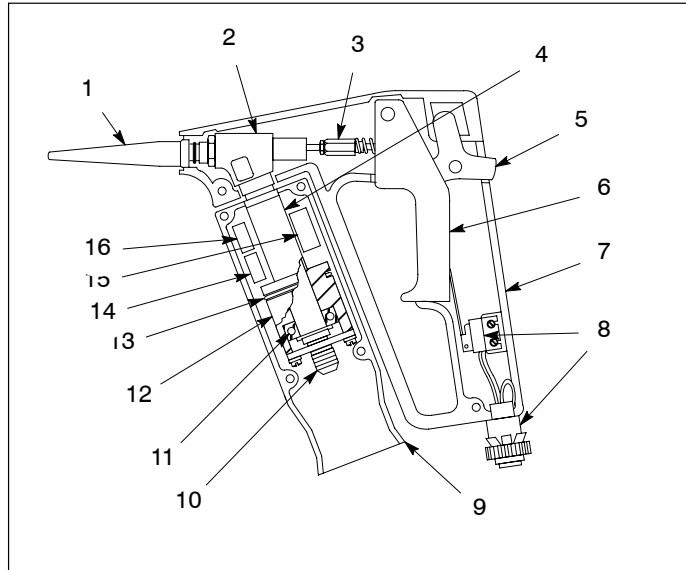

Figure 1 Typical Extrusion Handgun Assembly

- | | | |
|--------------------|---|--------------------------------------|
| 1. Nozzle | 7. Gun handle shells | 12. Pivot sleeve |
| 2. Gun body | 8. Switch plug assembly (B, C, and K guns only) | 13. Wire retaining clip |
| 3. Trigger linkage | 9. Pivot sleeve shells | 14. RTD terminal block or thermostat |
| 4. Ground screw | 10. Swivel connector | 15. Heater terminal block |
| 5. Trigger lock | 11. Thrust bearing | 16. Thermostat (L4 guns only) |
| 6. Trigger | | |

An impact-resistant molded shell ensures an extended service life. Guns features a 360-degree swivel connector to eliminate hose twisting.

Handguns use either a preset temperature sensor or an RTD (resistance temperature detector) sensor. RTD sensing reduces temperature fluctuations that affect flow and cause char formation. A wide operating range of 65 to 230 °C (150 to 450 °F) provides additional application versatility. RTD-style L4 guns have thermostats that are wired in series with the heaters.

For handling very thick adhesive, the AD-31 LBS extrusion handgun incorporates a large ball-and-seat and larger flow paths.

Standard Features

Standard features on AD-31 and L4 extrusion handguns include:

- compact and lightweight design
- ever-cool handle design
- compatibility with varying hose diameters
- 360-degree hose swivel for easy application without hose twisting
- safety lock on trigger

Optional Features

The following features are available with various extrusion handgun models:

- RTD sensing available on AD-31 handgun models B, C, K, T, and TL and some L4 handguns. Refer to Tables 2, 3, 4, and 5.
- microswitch for handgun models used with Series 5000 drum melters or gear-pump driven melters, available on AD-31 handgun models B, C, and K and some L4 handguns. Refer to Tables 2 and 3.
- LBS version for handling very thick adhesive, available on AD-31 handgun models B and K. Refer to Table 4.

Specifications

Table 2 AD-31 Handgun Specifications

Parameter	Value
Type of Pattern	Bead
Maximum operating temperature	230 °C (450 °F)
Maximum hydraulic pressure	10.34 mPa (1500 psi)
Nozzle orifice diameters: <ul style="list-style-type: none"> • standard • extended 	<ul style="list-style-type: none"> • 0.51 to 2.36 mm (0.020 to 0.093 in.) • .64 to 3.96 mm (0.025 to 0.156 in.)
Electrical requirements	100; 115; 120; 200; 220/240 VAC, 50/60 Hz
Weight	0.8 kg (1.75 lb)
Dimensions L x D x W mm (in.):	187.5 x 160.3 x 41.1 (7.38 x 6.31 x 1.62)

Table 3 L4 Handgun Specifications

Parameter	Value
Type of pattern	Bead
Adhesive viscosity	25,000 cps maximum
Weight	0.8 kg (1.75 lb)
Dimensions L x D x W mm (in.)	187.5 x 160.3 x 41.1 (7.38 x 6.31 x 1.62)
Operating temperature	37–230 °C (100–446 °F)
Storage temperature	-30–70 °C (-22–158 °F)
Warm-up time	30–45 min
Operating pressure	10.34 kPa (500 psi) maximum
Input voltage	115 VAC, 50/60 Hz or 230 VAC, 50/60 Hz
Power requirements	80 W
Heater type	Replaceable cartridge
RTD type (if applicable)	100-ohm platinum
Temperature control	Fixed, bimetallic thermostat with values from 93–218 °C (200–425 °F) or RTD sensor in gun with controller in melter, adjustable from 37–230 °C (100–450 °F)

Handgun Selection

Table 4 AD-31 Handgun Selection Chart

Equipment Model	Part No.	Gun Model	Hose Diameter (in.)	Seat	Voltage	Wattage	Sensor Type
DuraBlue	307712 ^C	AD-31T	$\frac{5}{16}$	SBS	120	80	RTD
	725953 ^B	AD-31STR-WP			120		
	274765 ^C	AD-31T			240		
	174933	AD-31T-PA			240		
	274752 ^C	AD-31TL			200		
	175299 ^C	AD-31TL-PA			200		
2300, 3000, 6000, FM130, and FM170	274765 ^A	AD-31T	$\frac{5}{16}$	SBS	240	80	RTD
	274752 ^A	AD-31TL	$\frac{5}{16}$	SBS	200	80	RTD
2000	272790 ^A	AD-31D	$\frac{5}{16}$	SBS	230	60	190 °C (375 °F) thermostat
	274419 ^A	AD-31L	$\frac{5}{16}$	SBS	200	60	190 °C (375 °F) thermostat
Roman Numerals (except Model X)	271612	AD-341A	$\frac{1}{4}$	SBS	230	60	190 °C (375 °F) thermostat
5000	271644	AD-31B	$\frac{5}{8}$	LBS	230	60	190 °C (375 °F) thermostat
	336241	AD-31B	$\frac{5}{8}$	LBS	230	80	RTD
	111354 ^A	AD-31C	$\frac{5}{16}$	SBS	230	80	RTD
	271645	AD-31C	$\frac{5}{16}$	SBS	230	60	190 °C (375 °F) thermostat
	121325 ^A	AD-31K	$\frac{5}{16}$	LBS	230	80	RTD
	276577	AD-31K	$\frac{5}{16}$	LBS	230	60	190 °C (375 °F) thermostat
	113183	AD-31K	$\frac{5}{16}$	LBS	230	60	65 °C (150 °F) thermostat
Model 115 and Hot Shot	276028	AD-31E	$\frac{5}{16}$	SBS	100	65	190 °C (375 °F) thermostat
Model 115A	274940	AD-31P	$\frac{5}{16}$	SBS	100	65	190 °C (375 °F) thermostat
Model 115B	276799	AD-31D	$\frac{5}{16}$	SBS	230	60	190 °C (375 °F) thermostat
<p>NOTE A: Used with hoses that have corrugated plastic outer covers. B: Used with polyamide materials. C: Used with hoses having corrugated covers.</p>							

Table 5 L4 Handgun Selection Chart (See Note A)

Equipment Model	Part No.	O-Ring	Switched/Unswitched	Voltage	Wattage	Sensor
Former Slautterback units	182032	Viton	Unswitched	115	80	190 °C (375 °F) thermostat
	182033	Viton	Unswitched	230	80	190 °C (375 °F) thermostat
	182034	Viton	Switched	115	80	RTD (see Note B)
	182035	Viton	Switched	230	80	RTD (see Note B)
	1020528	Viton	Unswitched	115	80	RTD (see Note B)
	1020529	Viton	Unswitched	115	80	149 °C (300 °F) thermostat
	1020530	Viton	Unswitched	230	80	177 °C (350 °F) thermostat
	1020533	Kalrez	Unswitched	230	80	218 °C (425 °F) thermostat
	1020534	Viton	Unswitched	230	80	RTD (see Note B)
	1020535	Kalrez	Unswitched	230	80	RTD (see Note B)
	1020536	Viton	Switched	115	80	190 °C (375 °F) thermostat
	1020538	Viton	Switched	230	80	190 °C (375 °F) thermostat

NOTE A: All L4 handguns have a small ball-and-seat configuration and are standard bottom-feed only.

B: All RTD-controlled L4 handguns have a 218 °C (450 °F) thermostat for overtemperature protection and 100-ohm platinum RTDs.

Installation



WARNING: Allow only qualified personnel to perform the following tasks. Follow the safety instructions in this document and all other related documentation.

This section provides safety and installation information for installing handguns.

Hose/Gun Connection



WARNING: Hot! Risk of burns. Wear heat-protective clothing, safety goggles, and heat-protective gloves.

Connect the Hose

Handguns are shipped fully assembled. To connect the hose to the handgun, partially disassemble the handgun.

1. With a Phillips screwdriver, remove the screws that secure the pilot sleeve shells.

NOTE: Figure 2 shows a typical handgun. Details may vary depending upon the gun model.

2. Remove the cap plug on the swivel connector.

CAUTION: Align each set of electrical wires exiting the hose with a groove on the pivot sleeve. Failure to do so can damage the wires, resulting in an electrical short. See Figure 3.

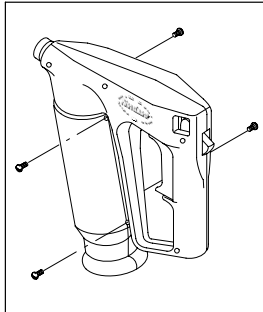

Figure 2 Remove Pivot Sleeve Shells (typical gun shown)

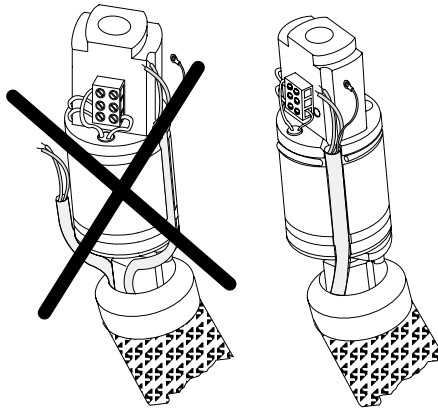

Figure 3 Proper Wire Alignment

NOTE: Handguns with a thermostatic sensor use only one set of electrical wires.

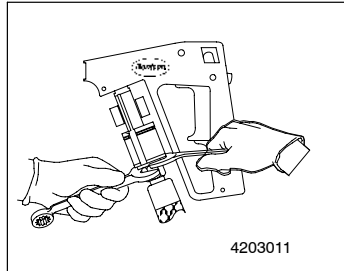

Figure 4 Attach the Hose to the Handgun (electrical connections not shown for clarity)

3. See Figure 4. Attach the hose fitting to the swivel connector, and tighten using two wrenches. Place a 20-mm ($3/4$ -in.) wrench on the wing of the swivel connector, and tighten the hose fitting using the 18-mm ($11/16$ -in.) wrench.

CAUTION: An electric short can occur if wires do not lie flat and side by side, not crossing each other within the groove.

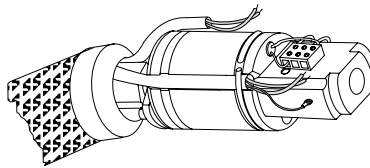

Figure 5 Secure the Wires with the Retaining Clip

4. See Figure 5. Rotate the wire retaining clip around the pivot sleeve so that the clip's opening aligns with one of the grooves on the pivot sleeve.
5. Place one set of wires into the groove and rotate the wire retaining clip so that it holds the wires securely in the groove. For handguns with electrical configurations A or B (refer to Table 6), repeat steps 4 and 5 to secure the other set of wires.

Electrical Connections

Before connecting the hose to the melter, make electrical connections as described in the following procedures.

Connections for Specific Handgun Configurations

To make the electrical connections for the handgun, refer to the appropriate procedure shown in Table 6.

Table 6 Correct Electrical Connection Procedure for Each Handgun Model

Handgun Model	Sensor Type	Refer to...
AD-31	RTD (for use with a Series 5000 melter)	Configuration A (RTD-Style AD-31, Series 5000)
	RTD (for use with any melter other than a Series 5000 melter)	Configuration B (RTD-Style AD-31, Other Than Series 5000)
	Thermostat	Configuration C (Thermostat-Style AD-31)
L4	RTD	Configuration D (RTD-Style L4 Handgun)
	Thermostat	Configuration E (Thermostat-Style L4 Handgun)

Configuration A: RTD-Style AD-31, Series 5000

Connect the RTD Sensor

Refer to the Figure 6 as necessary.

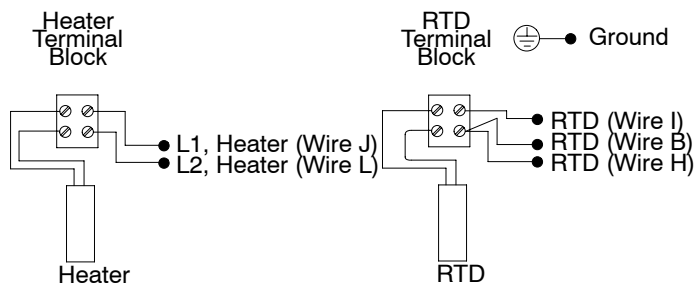

Figure 6 Wiring Diagram

1. Loosen the three screws from the RTD terminal block as shown in Figure 7. Insert wires I, H, and B, extending from the hose, into the RTD terminal block.

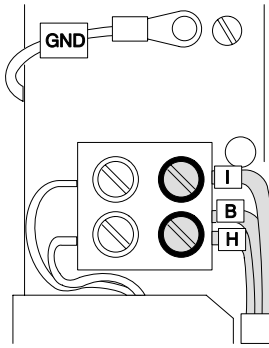

Figure 7 Connect the RTD

2. Tighten the three terminal-block screws to 0.42 N•m (3.7 in.-lb). Do not overtighten.
3. Remove the ground screw from the pivot sleeve.



WARNING: Electrical shock hazard exists if hose ground wire is not secured tightly to the gun body.

4. Secure the ground wire to the RTD side of the pivot sleeve. Do not overtighten.

Connect the Heater

1. On the heater side of the pivot sleeve, loosen the two screws on the heater terminal block as shown in Figure 8. Insert wires L and J, extending from the hose, into the terminal block.

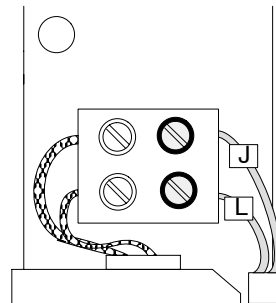

Figure 8 Connect the Heater

2. Tighten the two terminal-block screws to 0.42 N•m (3.7 in.-lb). Do not overtighten.

CAUTION: Do not pinch wires between the shells and the pivot sleeve. An electrical short can occur.

3. Replace the pivot sleeve shells and secure with screws.

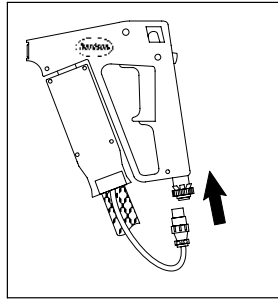

Figure 9 Connect the Electrical Switch

Electrical Switch Connections (if applicable)

1. Find the orientation lug on the hose-cordset connector and ensure that the connector and switch plug at the bottom of the handgun's handle are properly aligned.
2. Attach the switch plug assembly at the bottom of the handle to the connector on the hose cordset.
3. Refer to the melter manual to complete the hose installation to the melter.

Configuration B: AD-31 RTD Style Other than Series 5000

Connecting the RTD Sensor

Refer to Figure 10 as necessary.

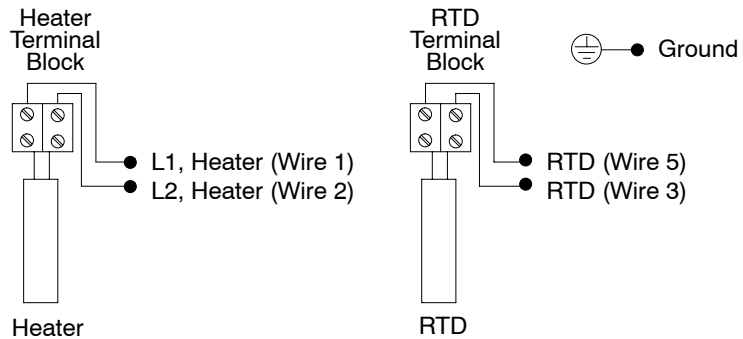

Figure 10 Wiring Diagram

1. Loosen the two screws from the RTD terminal block as shown in Figure 11. Insert wires 3 and 5, extending from the hose, into the terminal block.

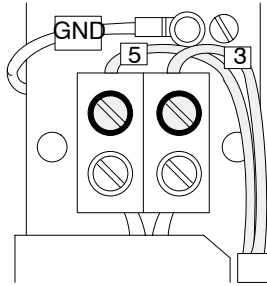

Figure 11 Connect the RTD

2. Tighten the terminal-block screws to 0.42 N•m (3.7 in.-lb.). Do not overtighten.
3. Remove the ground screw from the pivot sleeve.



WARNING: Risk of shock! The hose ground wire must be secured tightly to the gun body. Failure to do so can result in injury or death.

4. Secure the ground wire to the RTD side of the pivot sleeve. Do not overtighten.

Connect the Heater

1. On the heater side of the pivot sleeve, loosen the two screws on the heater terminal block as shown in Figure 12. Insert wires 1 and 2, extending from the hose, into the terminal block.

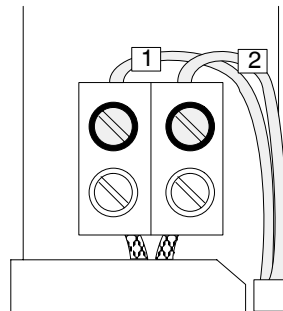

Figure 12 Connect the Heater

2. Tighten the two terminal-block screws to 0.42 N•m (3.7 in.-lb.). Do not overtighten.

CAUTION: Do not pinch wires when replacing the pivot-sleeve shells. An electrical short can occur.

3. Replace the pivot sleeve shells and secure with screws.

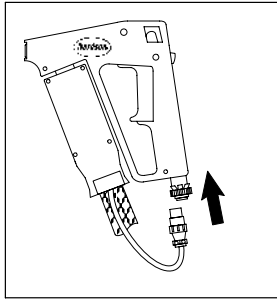

Figure 13 Connect the Electrical Switch

Electrical Switch Connections (if applicable)

1. Find the orientation lug on the hose-cordset connector and ensure that the connector and switch plug at the bottom of the handgun's handle are properly aligned.
2. Attach the switch plug assembly at the bottom of the handle to the connector on the hose cordset.
3. Refer to the melter manual to complete the hose installation to the melter.

Configuration C: Thermostat Style AD-31

Connecting the Heater

Refer to Figure 14 as necessary.

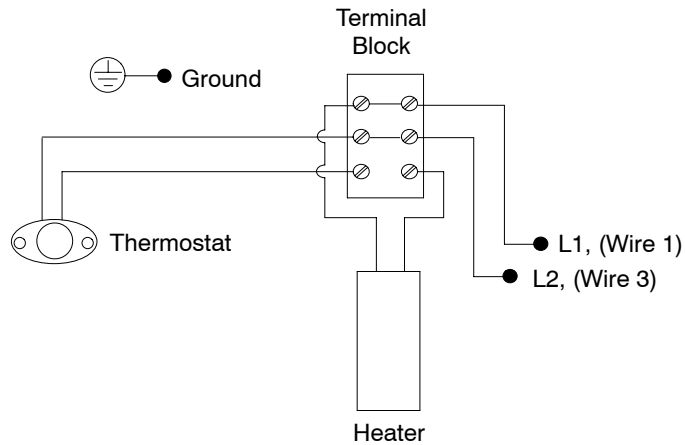

Figure 14 Wiring Diagram

NOTE: The thermostatic sensor is factory prewired.

1. Loosen the two screws from the terminal block as shown in Figure15. Insert wires 1 and 3, extending from the hose, into the terminal block.

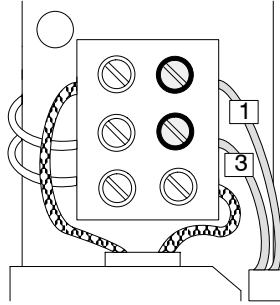

Figure 15 Connect the Heater

2. Tighten the two terminal-block screws to 0.42 N•m (3.7 in.-lb). Do not overtighten.
3. On the thermostat side of the pivot sleeve, remove the ground screw from the pivot sleeve.

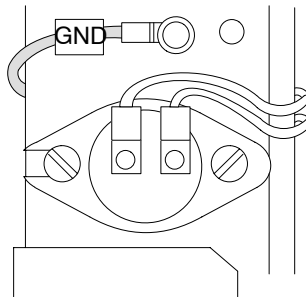

Figure 16 Remove the Ground Screw



WARNING: Risk of shock! The hose ground wire must be secured tightly to the gun body. Failure to do so can result in injury or death.

4. Insert the ground wire, extending from the hose, into the screw hole on the RTD side of the pivot sleeve. Secure the wire by replacing and tightening the screw. Do not overtighten.

CAUTION: Do not pinch wires between the shells and the pivot sleeve. An electrical short can occur.

5. Replace the pivot sleeve shells and secure with screws.

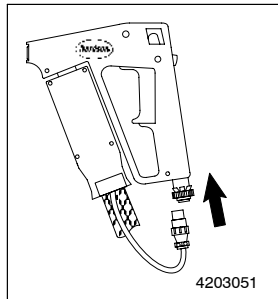

Figure 17 Connect the Electrical Switch

Electrical Switch Connections (if applicable)

1. Find the orientation lug on the hose-cordset connector and ensure that the connector and switch plug at the bottom of the handgun's handle are properly aligned.
2. Attach the switch plug assembly at the bottom of the handle to the connector on the hose cordset.
3. Refer to the melter manual to complete the hose installation to the melter.

Configuration D: RTD-style L4

Connecting the RTD Sensor

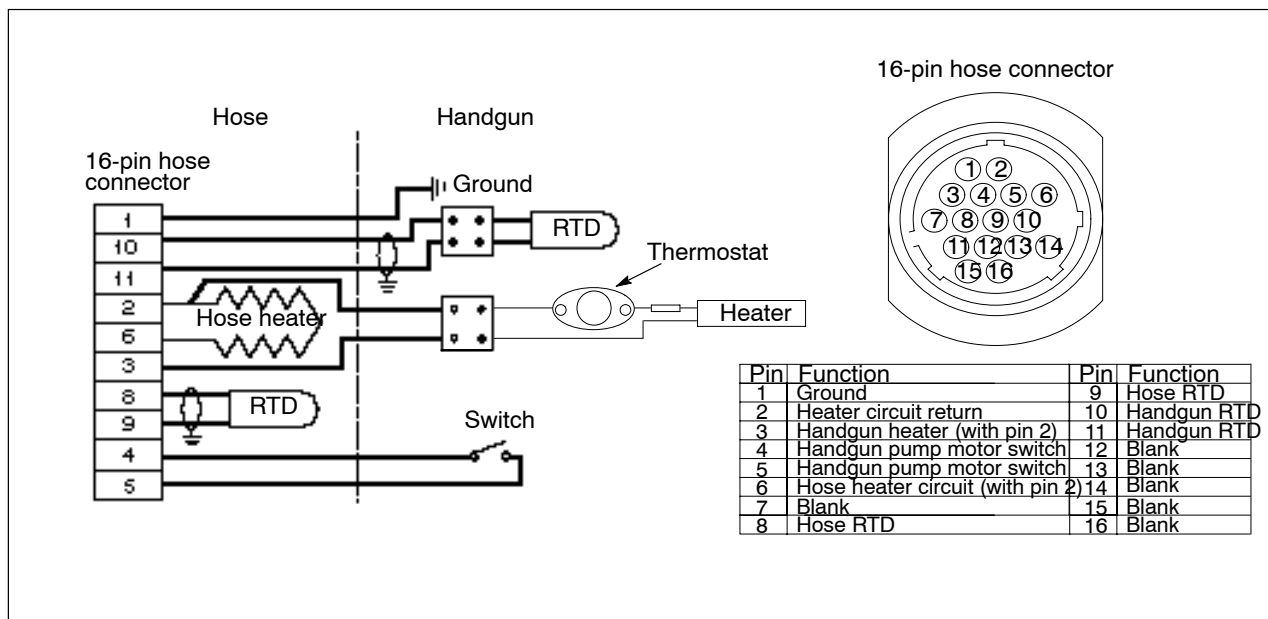

Figure 18 Wiring Diagram

1. Connect the hose electrically as shown in Figure 18.
2. Loosen the two screws from the RTD terminal block. Insert wires 10 and 11, extending from the hose, into the terminal block.
3. Tighten the terminal-block screws to 0.42 N•m (3.7 in.-lb.), taking care not to overtighten.
4. Remove the ground screw from the pivot sleeve.



WARNING: Risk of shock! The hose ground wire must be secured tightly to the gun body.

5. Secure the ground wire to the RTD side of the pivot sleeve. Do not overtighten.

Connect the Heater

1. On the heater side of the pivot sleeve, loosen the two screws on the heater terminal block. Insert wires 2 and 3, extending from the hose, into the terminal block.
2. Tighten the two terminal-block screws to 0.42 N•m (3.7 in.-lb.), taking care not to overtighten.

CAUTION: Do not pinch wires between the shells and the pivot sleeve. An electrical short can occur.

3. Replace the pivot sleeve shells and secure with screws.

Electrical Switch Connections (if applicable)

1. Find the orientation lug on the hose-cordset connector and ensure that the connector and switch plug at the bottom of the handgun's handle are properly aligned.
2. Attach the switch plug assembly at the bottom of the handle to the connector on the hose cordset.
3. Refer to the melter manual to complete the hose installation to the melter.

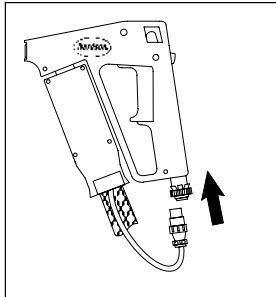

Figure 19 Connect the Electrical Switch

Configuration E: Thermostat-style L4**Connect the Heater**

Figure 20 Wiring Diagram

NOTE: The thermostatic sensor is factory prewired.

1. Connect the hose electrically as shown in Figure 20.
2. Loosen the two screws from the terminal block. Insert wires 2 and 3, extending from the hose, into the terminal block.
3. Tighten the terminal-block screws to 0.42 N•m (3.7 in.-lb). Do not overtighten.
4. On the thermostat side of the pivot sleeve, remove the ground screw from the pivot sleeve.

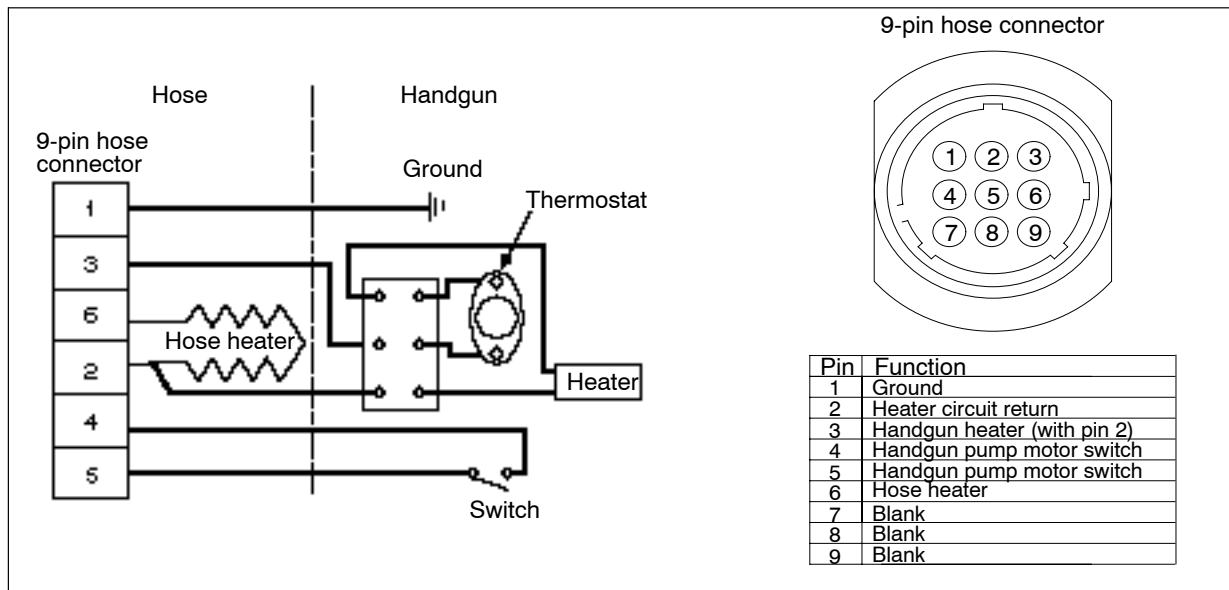

WARNING: Electrical shock hazard exists if hose ground wire is not secured tightly to the gun body.

5. Insert the ground wire, extending from the hose, into the screw hole on the thermostat side of the pivot sleeve. Secure the wire by replacing and tightening the screw. Do not overtighten.

CAUTION: When replacing the pivot-sleeve shells, do not pinch wires between the shells and the pivot sleeve. An electrical short can occur if wires are pinched.

6. Replace the pivot sleeve shells and secure with screws.

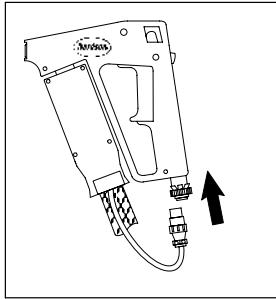

Figure 21 Connect the Electrical Switch

Electrical Switch Connections (if applicable)

1. Find the orientation lug on the hose-cordset connector and ensure that the connector and switch plug at the bottom of the handgun's handle are properly aligned.
2. Attach the switch plug assembly at the bottom of the handle to the connector on the hose cordset.
3. Refer to the melter manual to complete the hose installation to the melter.

Operation



WARNING: Allow only qualified personnel to perform the following tasks. Follow the safety instructions in this document and all other related documentation.



WARNING: Do not operate the hot melt system at pressures capable of causing the adhesive to extrude more than 46 cm (18 in.) from the nozzle tip when the handgun is fired in the horizontal position. Doing so can harm personnel or equipment and cause poor pattern control.

NOTE: The recommended adhesive pump pressure range is 2.41–4.83 mPa (350–700 psi).

The following factors can cause adhesive to project beyond the maximum recommended projection limit:

- increasing pump pressure
- increasing melter temperature
- changing the adhesive's consistency
- changing to a smaller size nozzle orifice
- changing the hose length



WARNING: Hot! Risk of burns. Wear heat-protective clothing, safety goggles, and heat-protective gloves. Never point the handgun at anyone. Trigger the handgun only when adhesive is to be applied to a substrate.



WARNING: Do not operate the handgun with its pivot sleeve shells or handles removed or damaged. The handgun contains voltages that can be fatal.

CAUTION: Do not swivel or trigger the handgun while it is cold. Damage can occur.

CAUTION: Aggressive motion of the hose and handle can damage a handgun with a microswitch, take care when swiveling the handgun.

Startup



WARNING: Risk of burns. Leave the trigger safety in the locked position to prevent inadvertent discharge during startup until completing the startup procedure.

1. See Figure 22. Make sure the trigger safety is locked.

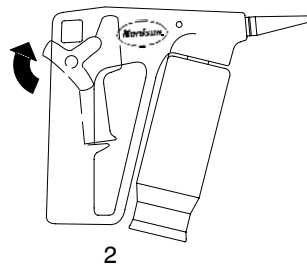
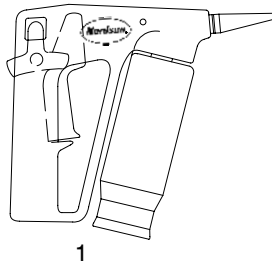

Figure 22 Lock Positions

1. Unlocked

2. Locked

2. Bring the adhesive to operating temperature, and then turn on the melter pump.

NOTE: On standard models, the pump is continuously running. On models with an electrical switch, the pump runs when the handgun is triggered.

3. Adjust the system hydraulic pressure to the required operating pressure.

Operation

1. Place the trigger lock in the unlocked position. See Figure 22.
2. Point the nozzle at the substrate.
3. Squeeze the handgun trigger to dispense adhesive.
4. Release the trigger to stop dispensing adhesive.

Shutdown

1. Place the trigger in the locked position. If necessary, see Figure 22.
2. Relieve system pressure. Refer to *Safety*.
3. Place the trigger lock in the unlocked position.
4. Place a waste container on the floor near the handgun's nozzle.
5. Drain adhesive from the handgun into the container until system hydraulic pressure is relieved and the handgun is drained of adhesive. Dispose of the drained adhesive.
6. Place the trigger in the locked position.



WARNING: Never hang the handgun by its trigger. Doing so can cause accidental discharge, resulting in burns.

7. Hang the handgun by the hole at the top of the handle.

Maintenance



WARNING: Allow only qualified personnel to perform the following tasks. Follow the safety instructions in this document and all other related documentation.

Preventive maintenance procedures for handguns consist of periodic inspections, cleaning, and changing out adhesive.

CAUTION: Accumulated adhesive can char and cause erratic operation.



WARNING: Attempting any other maintenance procedure than those described in this section can cause personal injury, handgun damage, or improper system operation.



WARNING: Risk of death or serious injury from fire or toxic fumes. Cleaning fluids other than Type R may present a toxic or fire hazard even at room temperature.

Daily Maintenance



WARNING: Risk of death or serious injury from explosion or fire can occur if Nordson Type R fluid is heated above 245 °C (475 °F). Do not use Nordson Type R fluid on surfaces above 245 °C (475 °F).

NOTE: Nordson Type R fluid is used to clean adhesive from extrusion systems. Its advantages over similar fluids are that it can be reused and that it has an inoffensive odor.

1. Bring handgun to operating temperature.
2. Soak a cloth in Nordson Type R fluid (or equivalent).
3. Wipe adhesive from all exterior handgun and nozzle surfaces with the fluid-soaked cloth.

Weekly Maintenance

Clean all nozzles weekly unless operating experience mandates more frequent cleaning. Plant environment and the type of adhesive used are some factors that can affect cleaning frequency.

Required Items

- protective clothing
- cleaning cloth
- 13-mm ($1/2$ -in.) open-end wrench
- nozzle cleaning probe (included in Nordson nozzle-cleaning kit P/N 901915)
- controlled heating device, such as a small, deep fat fryer, thermostatically controlled hot plate, or an ultrasonic cleaning device
- Nordson Type R fluid (or equivalent)
- slotted scoop or wire basket

Nozzle Cleaning



WARNING: Hot! Risk of burns. Wear heat-protective clothing, safety goggles, and heat-protective gloves.

CAUTION: Nozzles can be damaged if an open torch, drill, or broach is used for cleaning. Use only a pin-type probe to clean a nozzle.

1. Relieve system pressure. Refer to *Safety*.



WARNING: Disconnect and lock out input power to the melter. Failure to do so can result in serious injury, including death.

2. Disconnect and lock out input power to the melter.
3. Place the trigger lock in the locked position.
4. Use a 13-mm ($1/2$ -in.) wrench and loosen the nozzle by turning it counterclockwise.
5. Remove the nozzle.



WARNING: Do not use Nordson Type R fluid on surfaces above 245 °C (475 °F). death or serious injury from explosion or fire can occur.

6. Place the nozzle in a container filled with Nordson Type R fluid (or equivalent) and heat the container to the adhesive's melting point.

NOTE: An ultrasonic cleaner filled with Nordson Type R fluid may also be used.

7. After the charred adhesive is removed from the nozzle, remove the nozzle from the container.

NOTE: To reuse Nordson Type R Fluid, allow the fluid to cool; then, skim the adhesive from the fluid and properly dispose of the adhesive. Return the remaining fluid to its original container, and store appropriately.

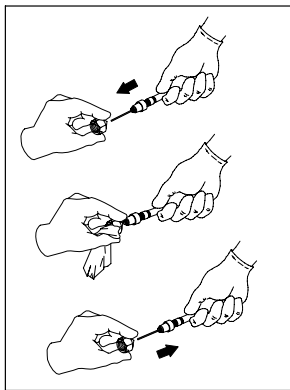

Figure 23 Use a Nozzle Probe

CAUTION: Use only a pin-type probe to clean a nozzle. Failure to do so can cause damage to the nozzle.

8. Clean the nozzle bore using a pin-type probe, and wipe with a cloth soaked in Nordson Type R fluid as needed.
9. Reattach the nozzle to the gun.
10. Restore the system to normal operation.

Semiannual Maintenance

Inspect the handgun twice a year as follows:

1. Relieve system pressure. Refer to *Safety*.



WARNING: Disconnect and lock out input power to the melter. Failure to do so can result in serious injury or death.

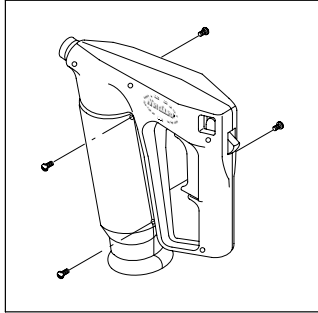

Figure 24 Remove Pivot Sleeve Shells (typical gun shown)

2. Disconnect and lock out input power.
3. See Figure 24. Use a Phillips screwdriver to unscrew the four screws holding the shells together.
4. Inspect all wiring for signs of wear or damage to the insulation.
5. Check all electrical connections for tightness and tighten if needed.

CAUTION: Do not pinch wires between the shells and the pivot sleeve. An electrical short can occur.

6. Replace the pivot sleeve shells and tighten the screws.
7. Restore the system to operation.

Troubleshooting



WARNING: Allow only qualified personnel to perform the following tasks. Follow the safety instructions in this document and all other related documentation.

This section provides answers to the most common problems that you may encounter. If you cannot solve the problem with the answers in this section, contact your Nordson representative for help.

Troubleshooting Table

Problem	Possible Cause	Corrective Action
1. No adhesive flow	Adhesive level low No input power Hose or melter temperature too low System not at operating temperature Insufficient air pressure to piston pump Gear pump motor not operational Failed heater fuse Pump switch off or failed (gear pump units only) Failed hose Hose clogged Nozzle clogged (except zero-cavity guns) Triggering device dirty or faulty	Check level. Add adhesive if needed. Connect power to the melter and accessories. Make sure that all circuit breakers are ON. Adjust setting. Verify READY light is on and adhesive or sealant is melted. Adjust. Verify motor operation. Check fuse and replace if bad. Turn on or replace the pump switch. Check hose heater cold resistance and replace hose if needed. Clean or replace hose. Clean nozzles. Replace if defective. Check trigger adjustment (refer to <i>Adjust the Trigger</i> or <i>Adjust the Trigger's Electrical Switch in Repair</i>). Clean or replace as needed.
2. Handgun overheats	Melter tank temperature setting too low Hose temperature controller setting too high Gun temperature controller setting too high Failed thermostat (open)	Adjust setting. Adjust setting. Adjust setting. Check continuity. Replace if needed (refer to <i>Replace the Thermostat in Repair</i>).

Continued...

Troubleshooting Table (contd)

Problem	Possible Cause	Corrective Action
	Failed RTD	Test RTD using Nordson hose/gun diagnostic device (P/N 132846). Replace if defective (refer to <i>Replace the RTD in Repair</i>). For appropriate RTD resistance ranges, see Figure 25 or 26.
3. Handgun fails to heat or underheats	No power Temperature setting too low Failed heater cartridge (open or short) Failed thermostat (open) Failed RTD	Make sure input power is connected and all circuit breakers switched ON. Adjust setting. Test resistance of cartridge. If outside the specified range of 797-931 ohm, replace (refer to <i>Replace the Heater Cartridge in Repair</i>). Check continuity. Replace if needed (refer to <i>Replace the Thermostat in Repair</i>). Test RTD using Nordson hose/gun diagnostic device (P/N 132846). Replace if defective (refer to <i>Replace the RTD in Repair</i>). For appropriate RTD resistance ranges, see Figure 25 or 26.
4. Handgun will not swivel	Thrust or pivot bearing binding	Check thrust or pivot bearing for binding. Lubricate or replace as needed (refer to <i>Replace the Swivel Bearing in Repair</i>).
5. Nozzle leaks	Triggering device improperly adjusted	Check trigger adjustment (refer to <i>Adjust the Trigger or Adjust the Trigger's Electrical Switch in Repair</i>). Clean or replace as needed.
6. Handgun fails to shut off	Triggering device improperly adjusted Foreign material lodged between seat and packing cartridge ball tip; packing cartridge failed	Check trigger adjustment (refer to <i>Adjust the Trigger or Adjust the Trigger's Electrical Switch in Repair</i>). Clean or replace as needed. Check the nozzle assembly (refer to <i>Replace the Packing Cartridge in Repair</i>). Clean or replace as needed.
7. Adhesive leaks from gun handle	Damaged seal ring Worn or damaged packing cartridge	Inspect and replace if damaged (refer to <i>Replace the Packing Cartridge in Repair</i>). Check the packing cartridge (refer to <i>Replace the Packing Cartridge in Repair</i>). Clean or replace as needed.
8. Adhesive leaks from pivot sleeve shells	Cracked or damaged swivel connector seal	Check seal for damage and replace the swivel connector seal and backup ring (refer to <i>Replacing the Swivel Bearing in Repair</i>).

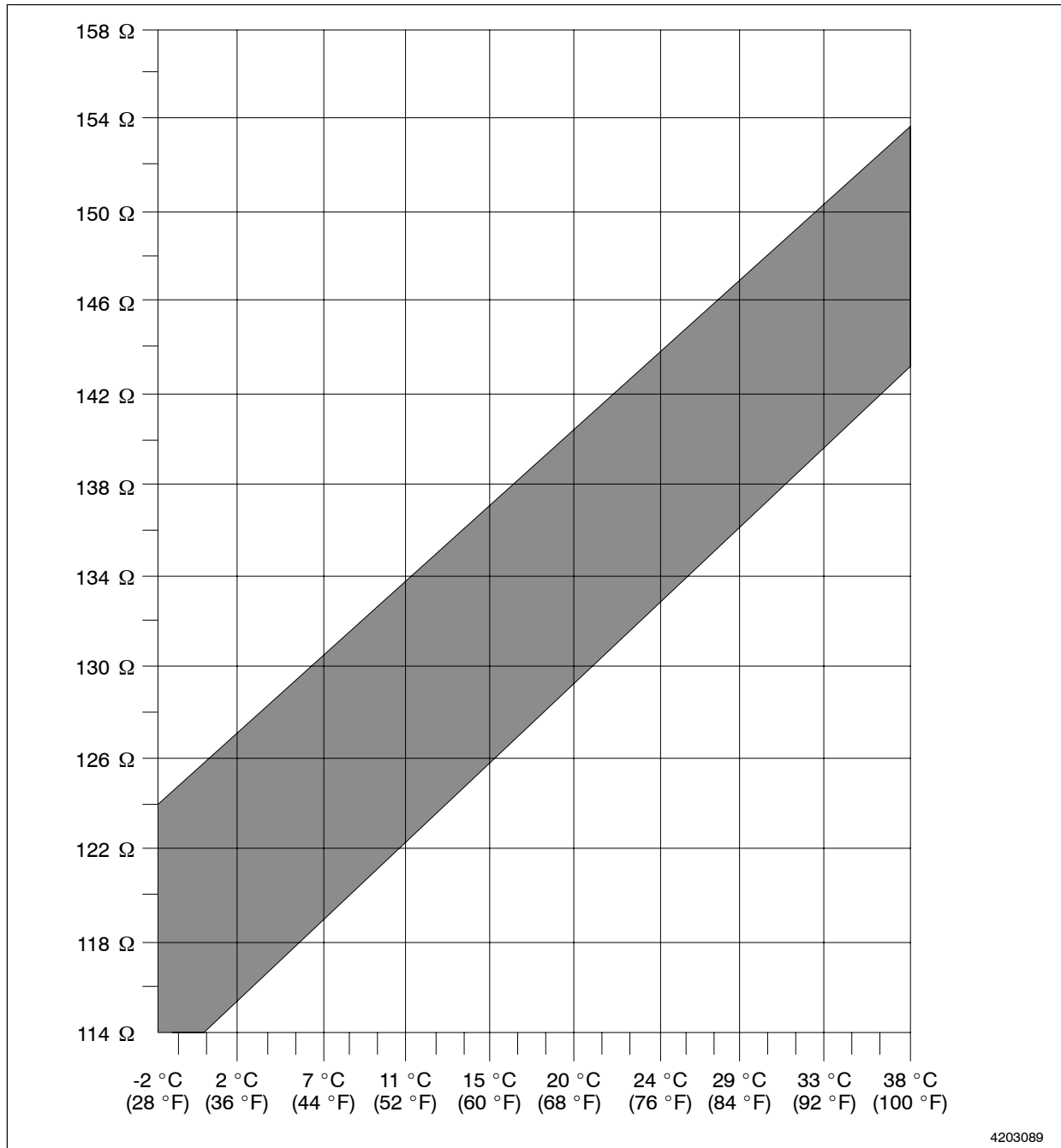

Figure 25 RTD Resistance vs. Temperature Chart for AD-31 Handguns (nickel RTDs)

Troubleshooting Table *(contd)*

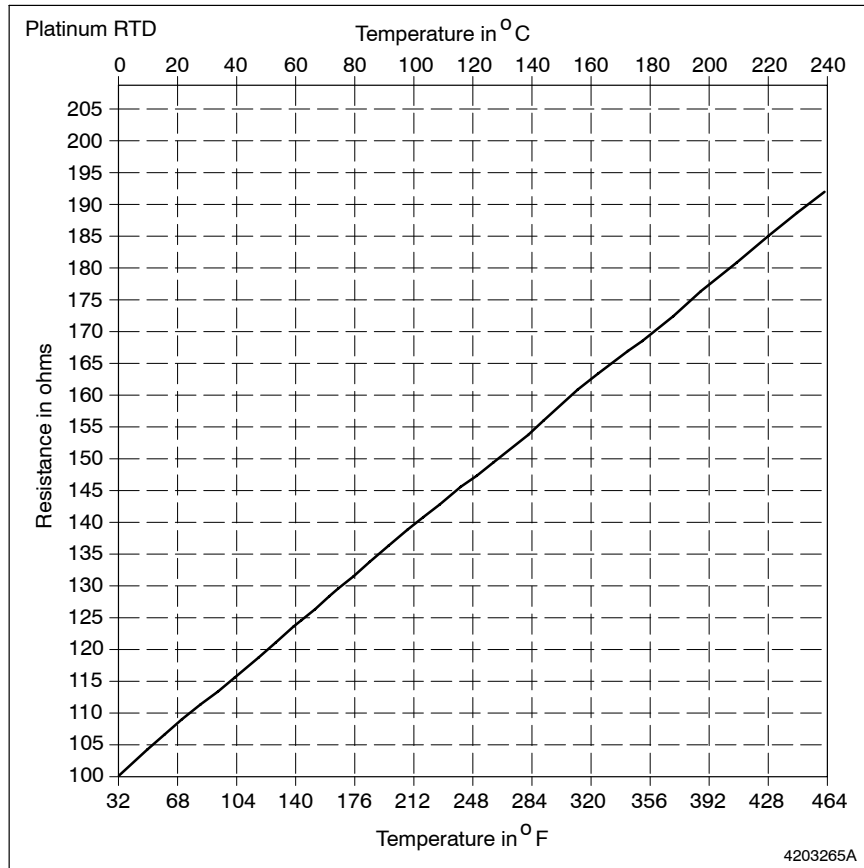

Figure 26 RTD Temperature vs. Resistance Chart for L4 Handguns (platinum RTDs)

Repair



WARNING: Allow only qualified personnel to perform the following tasks. Follow the safety instructions in this document and all other related documentation.

This section contains instructions for replacing handgun components. The instructions describe

- how to replace the RTD (resistance temperature detector) and thermostatic sensors, heater cartridge, packing cartridge, and swivel bearing
- how to adjust the trigger and electrical switch

Replace the RTD



WARNING: Hot! Risk of burns. Wear long-sleeved, heat-protective clothing; safety goggles; and heat-protective gloves.

1. Relieve system pressure. Refer to *Safety*.



WARNING: Disconnect and lock out input power. Failure to do so can result in serious injury, including death.

2. Disconnect and lock out input power to the melter main circuit breaker.

3. See Figure 27. Place the trigger in the locked position.

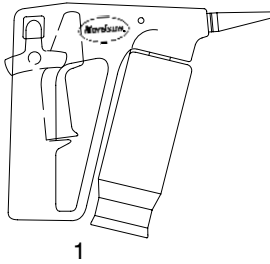

1

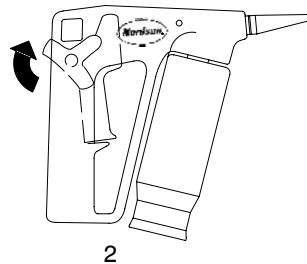

2

Figure 27 Lock Positions

1. Unlocked

2. Locked

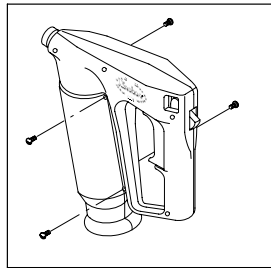

4. Use a Phillips screwdriver and unscrew the screws holding the pivot sleeve shells together.

NOTE: Figure 28 shows a typical handgun. Details may vary depending upon the gun model.

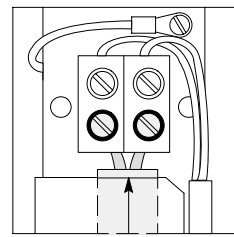

Typical RTD Removal

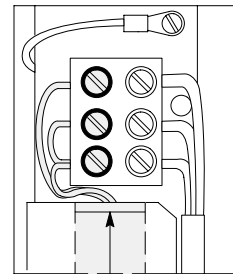

RTD Removal for a 3-Station Terminal Block

Figure 28 Remove the Pivot Sleeve Shells (typical gun shown)

Replace the RTD *(contd)*

5. Use a 3-mm ($\frac{1}{8}$ -in.) flat-blade screwdriver, and loosen the two screws connecting the RTD wires to the terminal block. Remove the RTD wires from the terminal block, slide the RTD sensor from the pivot sleeve, and properly dispose the sensor.
6. Apply heat-transfer paste to the replacement RTD sensor, and install the replacement. Connect the RTD wires to the terminal block as shown in Figure 28.
7. Replace the pivot sleeve shells. Insert and tighten the screws holding the shells together.
8. Restore the system to normal operation.

Replace the Thermostat



WARNING: Hot! Risk of burns. Wear long-sleeved, heat-protective clothing; safety goggles; and heat-protective gloves.

1. Relieve system pressure. Refer to *Safety*.



WARNING: Even when switched off, Nordson melters and guns contain electrical potentials that can cause death. Disconnect and lock out input power to the melter main circuit breaker.

2. Disconnect and lock out input power to the melter main circuit breaker.
3. See Figure 27. Place the trigger in the locked position.
4. Use a Phillips screwdriver and unscrew the screws holding the pivot sleeve shells together.
5. See Figure 29. Loosen the two screws connecting the thermostat wires to the terminal block. Remove the thermostat wires

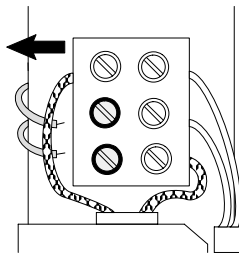
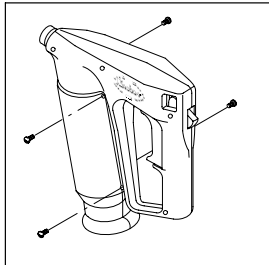

Figure 29 Disconnecting the Thermostat Wires

6. See Figure 30. Loosen the one screw securing the thermostat to the pivot sleeve. Slide the thermostat out.

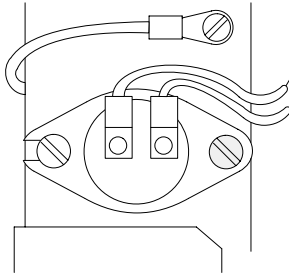

Figure 30 Remove the Thermostat from the Pivot Sleeve

7. Discard the thermostat and install the replacement thermostat.
8. See Figure 31. Connect the thermostat wires to the terminal block.

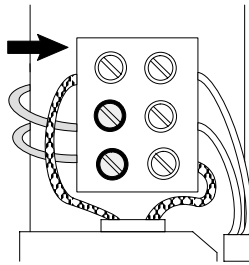

Figure 31 Connect the Thermostat Wires

9. Replace the pivot sleeve shells. Insert and tighten the screws holding the shells together.
10. Restore the system to normal operation.

Replace the Heater Cartridge



WARNING: Allow only qualified personnel to perform the following tasks. Read and follow the safety instructions in this document and all other related documentation.



WARNING: Hot! Risk of burns. Wear long-sleeved, heat-protective clothing; safety goggles; and heat-protective gloves.

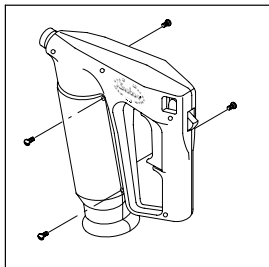

1. Disconnect and lock out input power to the melter main circuit breaker.
2. See Figure 27. Place the trigger in the locked position.
3. Use a Phillips screwdriver and unscrew the screws holding the pivot sleeve shells together.

Replace the Heater Cartridge *(contd)*



WARNING: Risk of shock! Disconnect and lock out input power to the melter main circuit breaker.

- See Figure 32. Unscrew the heater cartridge wires from the terminal block. Slide the heater cartridge out of the pivot sleeve.

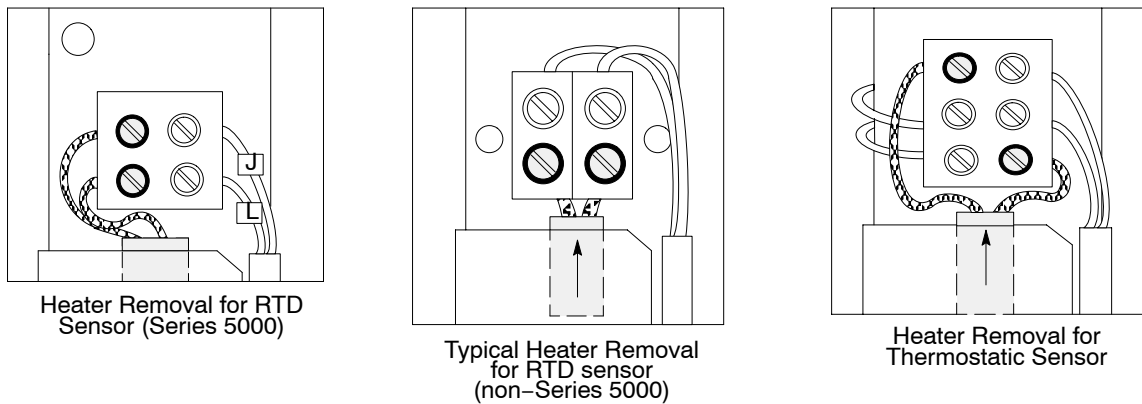

Figure 32 Remove the Heater Cartridge

NOTE: Because the handgun is constantly heated and cooled, the heater cartridge may become stuck in the pivot sleeve. If this occurs, remove the hose from the handgun and force the cartridge out from the bottom of the pivot sleeve. Refer to steps 6–8 of *Replace the Swivel Bearing* to remove the handgun from the hose and access the bottom of the heater cartridge.

- Install the replacement heater cartridge, and connect the heater cartridge wires to the terminal block as shown in Figure 32.
- Replace the pivot sleeve shells. Insert and tighten the screws holding the shells together.
- Restore the system to normal operation.

Replace the Swivel Bearing



WARNING: Hot! Risk of burns. Wear long-sleeved, heat-protective clothing; safety goggles; and heat-protective gloves.

1. Relieve system pressure. Refer to *Safety*.



WARNING: Risk of shock! Disconnect and lock out input power to the melter main circuit breaker.

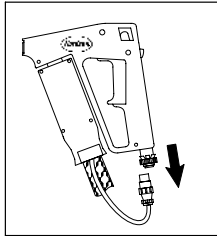

Figure 33 Disconnect the Electrical Switch (if applicable)

2. Disconnect and lock out input power.
3. Place the trigger in the locked position. See Figure 27.
4. See Figure 33. Unplug the switch plug assembly from the connector on the hose cordset.
5. Use a Phillips screwdriver and unscrew the screws holding the pivot sleeve shells together.

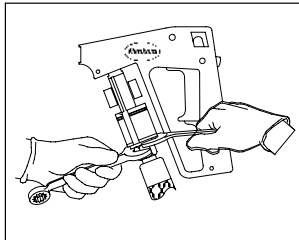

Figure 34 Removing the Hose from the Handgun

6. Disconnect electrical wires. Refer to *Electrical Connections in Installation* as needed.
7. Place a 20-mm ($3/4$ -in.) wrench on the wing of the swivel connector, and loosen the hose fitting using a 18-mm ($11/16$ -in.) wrench.

CAUTION: Handle the handgun carefully to avoid undue strain to the internal wiring or hose cordset.

Remove the Swivel Bearing

1. See Figure 35. Remove the two screws and washers holding the swivel connector to the pivot sleeve.

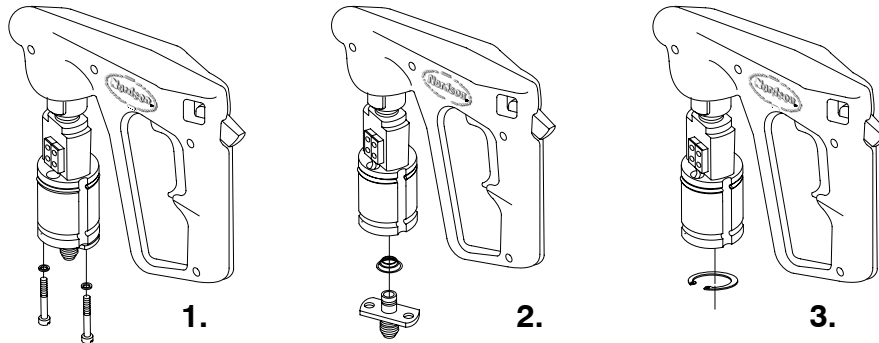

Figure 35 Swivel Connector Removal

2. Remove the swivel connector and conical spring from the pivot sleeve.
3. Remove the retaining ring from the thrust bearing using snap-ring pliers.
4. Remove the thrust bearing and retaining ring.
5. See Figure 36. Slide the pivot sleeve off the gun body.
6. Inspect the sleeve bearing for tears or worn spots and replace if necessary. Apply high-temperature grease to the gun body.

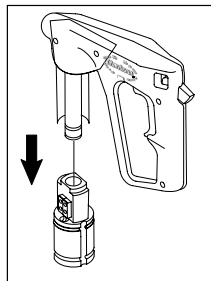

Figure 36 Remove the Pivot Sleeve

Reinstall the Swivel Bearing

1. Wrap the sleeve bearing around the gun body, and apply high-temperature grease to the outside of the sleeve bearing.
2. Slide the pivot sleeve onto the gun body and sleeve bearing.
3. Inspect the swivel connector, o-ring, and backup ring for pitting, hardening, or other damage. Replace if damaged.

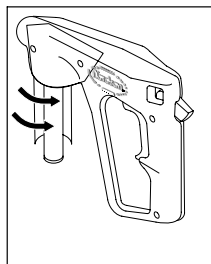

Figure 37 Replace the Sleeve Bearing

CAUTION: Use grease that is capable of withstanding 250 °C (500 °F). Standard greases char at high temperatures, causing the bearing to bind.

4. Clean the swivel connector o-ring and backup ring. Apply a high-temperature grease capable of withstanding 250 °C (500 °F). Wipe areas clean with a cloth as needed.
5. Clean the thrust bearing and apply high-temperature grease to the inside of the bearing.

CAUTION: Install the thrust bearing with the printed side of the bearing facing you and the retainer (loose piece) facing away from you, inside the sleeve. Installing the bearing upside down may cause this assembly to fail at normal operating pressure, resulting in an adhesive leak. Also, make certain to insert the conical spring small end first.

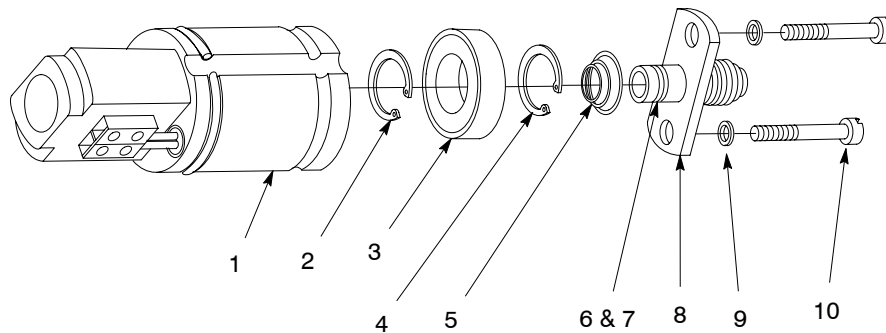

Figure 38 Thrust Bearing Assembly

- | | | |
|-------------------|-------------------|---------------------|
| 1. Pivot sleeve | 5. Conical spring | 8. Swivel connector |
| 2. Retaining ring | 6. O-ring | 9. Washers |
| 3. Thrust bearing | 7. Back-up ring | 10. Screws |
| 4. Retaining ring | | |

6. Reassemble the thrust bearing assembly as shown in Figure 38.
7. Rotate the pivot sleeve and allow the swivel connector to self-center.
8. Tighten the pivot-sleeve screws. Make sure that the pivot sleeve rotates easily.

CAUTION: Each set of electrical wires exiting the hose must align with a groove on the pivot sleeve. Improper alignment can damage the wires, resulting in a possible electrical short.

9. See Figure 39. Align the pivot sleeve and the hose with each set of wires exiting the hose. Make sure to route the set of wires containing the ground wire up the groove on the heater side of the pivot sleeve.

Reinstall the Swivel Bearing(contd)

NOTE: Handguns with a thermostatic sensor use only one set of electrical wires.

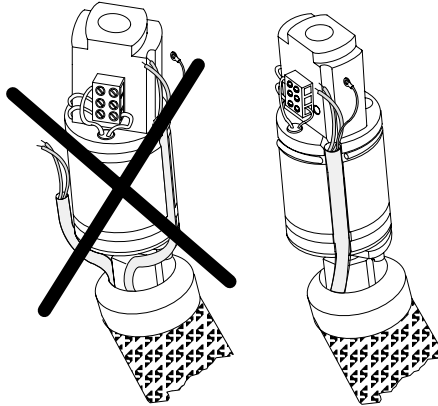

Figure 39 Proper Wire Alignment

10. Attach the hose fitting to the swivel connector. Place a 20-mm ($3/4$ -in.) wrench on the wing of the swivel connector, and tighten the hose fitting using the 18-mm ($11/16$ -in.) wrench.



WARNING: An electric short can occur if wires do not lie flat and side by side, not crossing each other within the groove.

11. Rotate the wire retaining clip around the pivot sleeve so that the clip's opening aligns with one of the grooves on the pivot sleeve.

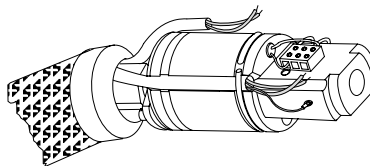

Figure 40 Secure the Wires with the Retaining Clip

12. Place one set of wires into the groove and rotate the wire retaining clip so that it holds the wires securely in the groove. To determine your handgun's configuration, refer to *Electrical Connections* in *Installation*.

13. Attach the switch's plug at the bottom of the trigger handle to the connector on the hose.

14. Replace the pivot sleeve shells. Insert and tighten the screws holding the shells together.

15. Restore the system to normal operation.

Replace the Packing Cartridge



WARNING: Hot! Risk of burns. Wear long-sleeved, heat-protective clothing; safety goggles; and heat-protective gloves.

1. Relieve system pressure. Refer to *Safety*.



WARNING: Risk of shock! Disconnect and lock out input power to the melter main circuit breaker.

2. Disconnect and lock out power to the main circuit breaker.

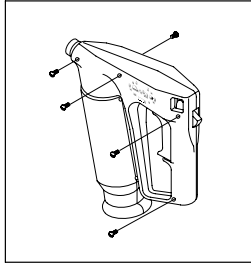

CAUTION: Never heat a component with a torch or other open flame. Use an electric oven with forced air circulation, or a flameless electric heat gun. Do not heat plastic shells above 230 °C (450 °F).

3. Remove the gun handle shell by unscrewing the screws holding the shells together.
4. Loosen the trigger linkage using two 10-mm ($\frac{3}{8}$ -in.) wrenches. Place one wrench on the locknut, the other on the trigger linkage, and turn the linkage to loosen.

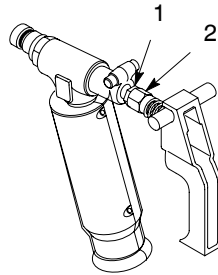

Figure 41 Loosen the Trigger

1. Locknut

2. Trigger linkage

Replace the Packing Cartridge *(contd)*

5. See Figure 42. Remove the pivot pin, and unscrew the trigger and linkage from the packing-cartridge assembly.

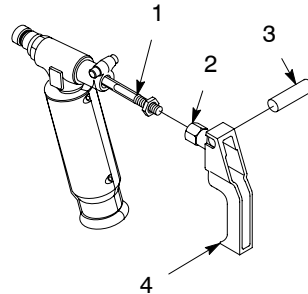

Figure 42 Remove the Trigger and Trigger Linkage (nozzle not shown)

- | | |
|----------------------|--------------|
| 1. Packing cartridge | 3. Pivot pin |
| 2. Trigger linkage | 4. Trigger |

6. See Figure 43. Unscrew and remove the nozzle, seat, and seal ring from the handgun body, leaving the o-ring on the seat.

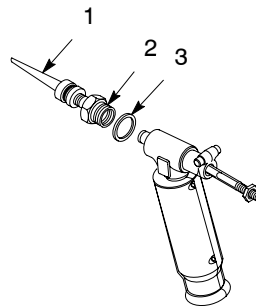

Figure 43 Nozzle Assembly (typical nozzle shown)

- | | |
|--------------------|--------------|
| 1. Nozzle | 3. Seal ring |
| 2. Seat and O-ring | |

7. Pull the packing cartridge out of the handgun body.
8. Discard the packing cartridge, and insert the replacement packing cartridge into the handgun body. Apply silicone lubricant to the packing cartridge.
9. Place the seal ring over the packing cartridge, the seat over the seal ring, and torque the seat to 34 N•m (25 ft-lb). Attach the nozzle to the seat.

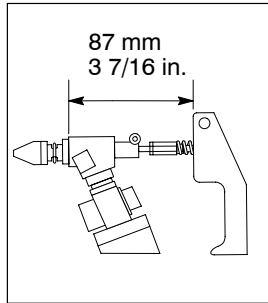

Figure 44 Trigger Adjustment

10. Reassemble the locknut and trigger linkage onto the packing-cartridge shaft.
11. Loosen or tighten the linkage until the distance between the edge of the trigger and the front end of the gun body (where the gun body meets the brass fitting) is 87 mm ($3 \frac{7}{16}$ in.).
12. Lock the linkage in place by tightening the locknut.
13. Replace the gun handle shells. Insert the screws into the shells' screw holes, and tighten.
14. Restore the system to normal operation by following the startup instructions in your melter product manual.

Adjust the Trigger



WARNING: Hot! Risk of burns. Wear long-sleeved, heat-protective clothing; safety goggles; and heat-protective gloves.

1. Relieve system pressure. Refer to *Safety*.



WARNING: Risk of shock! Disconnect and lock out input power to the melter main circuit breaker.

2. Disconnect and lock out input power to the melter main circuit breaker.
3. Remove the gun handle shells by unscrewing the screws holding the shells together.
4. Loosen the trigger linkage using two 10-mm ($\frac{3}{8}$ -in.) wrenches. Place one wrench on the locknut, the other on the trigger linkage, and turn the linkage to loosen.

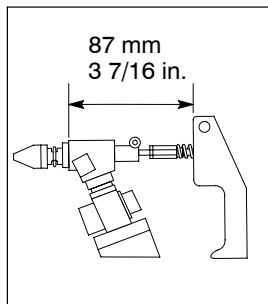
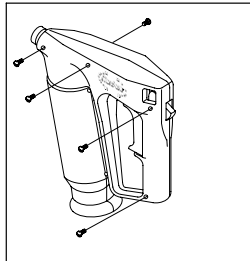

5. Adjust the linkage until the distance between the edge of the trigger and the front end of the gun body (where the gun body meets the brass fitting) is 87 mm ($3 \frac{7}{16}$ in.).
6. Lock the linkage in place by tightening the locknut.
7. Replace the gun handle shells.
8. Restore the system to normal operation.

Adjust the Trigger Electrical Switch



WARNING: Hot! Risk of burns. Wear long-sleeved, heat-protective clothing; safety goggles; and heat-protective gloves.

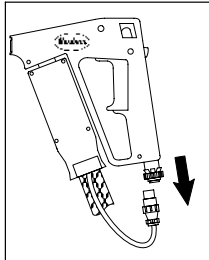

1. Relieve system pressure. Refer to *Safety*.
2. Disconnect and lock out input power.
3. Disconnect the electrical switch's plug from the connector on the hose.
4. Place the handgun on its right side.
5. Loosen the four screws holding the shells together and then remove the left gun handle shell. Leave the trigger assembly in the right gun handle shell.
6. See Figure 45. Set the ohmmeter at X1 scale and attach wires to pins 2 and 4 to test for proper electrical continuity.

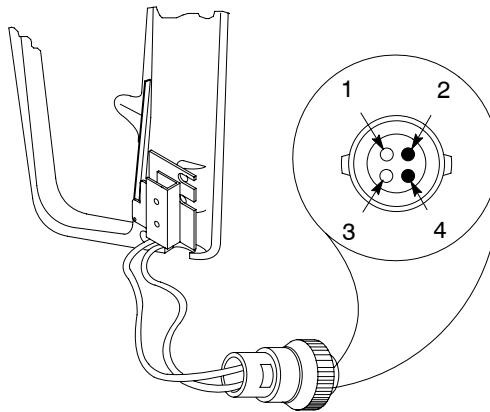

Figure 45 Check for Proper Electrical Continuity

7. Slowly depress the handgun trigger and watch for an indication of electrical continuity.

NOTE: The ohmmeter should indicate continuity when the packing cartridge shaft begins to move.

8. If continuity does not exist, loosen the switch's mounting screws and slide the switch toward or away from the trigger until continuity is indicated. See Figure 46.

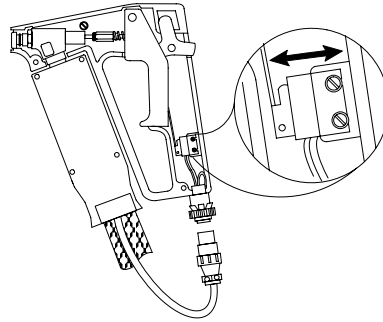

Figure 46 Adjust the Electrical Switch

9. When continuity is indicated, tighten the switch's mounting screws.
10. If continuity exists when the gun is not being triggered, repeat steps 7–9 until continuity exists only when the handgun is triggered.
11. Replace the left-side gun handle shell.
12. Find the orientation lug on the hose-cordset connector and ensure that the connector and switch plug at the bottom of the handgun's handle are properly aligned.
13. Attach the switch plug assembly at the bottom of the handle to the connector on the hose cordset.

Replace an Existing Gun

Remove the Existing Handgun

CAUTION: The Nordson handgun, sensor, and cordset are not compatible with similar components of other brands. Install a cordset conversion kit. Possible hazards include runaway temperature and failure to obtain an adequate ground.



WARNING: Risk of burns. Failure to relieve system pressure can result in hot adhesive spraying from a connecting point.

1. Relieve system pressure. Refer to *Safety*.

Remove the Existing Handgun (contd)



WARNING: Risk of electrical shock. Failure to observe this warning can result in personal injury or death.

2. Set the main circuit breaker or the disconnect switch to the OFF position.
3. Disconnect and lock out the input power line.
4. Unscrew the nozzle from the handgun and set it aside.
5. Unplug the switch's plug from the connector on the hose (if applicable).
6. Remove the pivot sleeve shells, and unscrew the screws holding the shells together.
7. Disconnect electrical wires. Refer to *Electrical Connections in Installation*.
8. Rotate the wire retaining clip so that the clip's opening aligns with one of the grooves on the pivot sleeve; dislodge the electrical wires from the groove. If your handgun uses configurations A or B, repeat this step to dislodge the other set of electrical wires.
9. Disconnect the hose from the gun using two wrenches. Place a 20-mm ($\frac{3}{4}$ -in.) wrench on the wing of the swivel connector, and loosen the hose fitting using a 18-mm ($\frac{11}{16}$ -in.) wrench.
10. Properly dispose of the handgun.

Install the New Handgun

CAUTION: Each set of electrical wires exiting the hose must align with a groove on the pivot sleeve. Improper alignment can damage the wires, resulting in a possible electrical short.

1. Align the pivot sleeve and the hose so that the grooves along the sides of the pivot sleeve line up with each set of wires exiting the hose.

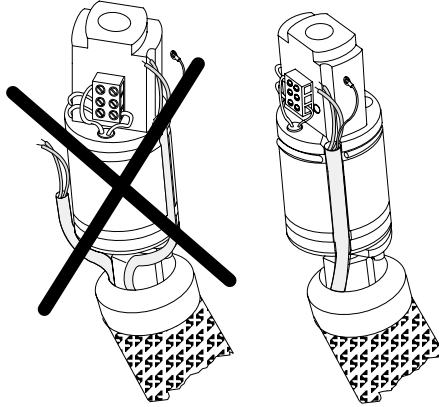

Figure 47 Proper Wire Alignment

NOTE: Handguns with a thermostatic sensor use only one set of electrical wires.

2. Attach the hose fitting to the swivel connector, and tighten using two wrenches.

CAUTION: An electric short can occur if wires do not lie flat and side by side, not crossing each other within the groove.

3. Rotate the wire retaining clip around the pivot sleeve so that the clip's opening aligns with one of the grooves on the pivot sleeve.

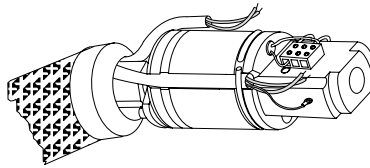

Figure 48 Secure the Wires with the Retaining Clip

4. Place one set of wires into the groove and rotate the wire retaining clip so that it holds the wires securely in the groove. If the handgun uses configurations A or B, repeat steps 5 and 6 to secure the other set of wires. To determine your handgun's configuration, refer to *Electrical Connections* in Section 3, *Installation*.
5. Refer to *Electrical Connections* in *Installation* to complete installation.
6. Attach the electrical switch's plug (if applicable) to the connector on the hose.
7. Replace the pivot sleeve shells.
8. Replace the nozzle.

Check for Leaks

1. Restore electrical power to the melter
2. Turn on the melter circuit breaker.
3. Let the melter and hose reach operating temperature.
4. Check for leaks between the hose fitting and the gun fitting.
5. On gear-pump units, increase motor speed to normal operating speed and check for leaks. On all other units, slowly restore air pressure to the melter to 0.28 MPa (40 psi) and check for leaks.
6. Tighten fittings as necessary.
7. Resume normal operation.

Using the Illustrated Parts Lists

To order parts, call the Nordson Customer Service Center or your local Nordson representative. Use these five-column parts lists, and the accompanying illustrations, to describe and locate parts correctly. The following chart provides guidance for reading the parts lists.

The number in the *Item* column corresponds to the circled item number in the parts list illustration. A dash in this column indicates that the item is an assembly.

The number in the *Part* column is the Nordson part number you can use to order the part. A series of dashes indicates that the part is not saleable. In this case, you must order either the assembly in which the part is used or a service kit that includes the part.

The *Description* column describes the part and sometimes includes dimensions or specifications.

The *Note* column contains letters that refer to notes at the bottom of the parts list. These notes provide important information about the part.

The *Quantity* column tells you how many of the part is used to manufacture the assembly shown in the parts list illustration. A dash or AR in this column indicates that the amount of the item required in the assembly is not quantifiable.

Item	Part	Description	Quantity	Note
—	0000000	Assembly A	—	
1	000000	• Part of assembly A	2	A
2	-----	• • Part of item 1	1	
3	0000000	• • • Part of item 2	AR	
NS	000000	• • • • Part of item 3	2	

NOTE A: Important information about item 1

AR: As Required

NS: Not Shown

Handgun Parts Lists

AD-31 Model K Handgun Parts

See Figure 49.

Item	Part	Description	Quantity	Note
—	113183	Handgun, AD-31K, 65 °C (150 °F) thermostat	—	
—	121325	Handgun, AD-31K, RTD	—	
—	276577	Handgun, AD-31K, 190 °C (375 °F) thermostat	—	
1	—	Cap/plug, tapered	1	
2	940133	O-ring, Viton, 0.438 x 0.563 x 0.063 in.	1	
3	273003	Seat, carbide	1	
4	152987	Seal, ring, seat	1	
5	271678	Cartridge, packing	1	
6	273002	Body, gun	1	
7	984120	Nut, hex, 10-32	1	
8	271616	Linkage, trigger	1	
9	271617	Spring, compression, 0.620 x 0.455 OD x 0.039 in.	1	
10	271618	Trigger, gun	1	
11	985216	Pin, dowel, 0.250 x 1.250 in.	1	
12	981014	Screw, pan, 4-40 x 0.250 in.	2	
13	983526	Washer, lock, split	2	
14	111583	Plug with switch, 3-pin (includes protective boot)	1	A, B
14	274376	Plug, switch (includes protective boot)	1	C
15	271626	Plate, bearing	1	
16	981817	Screw, shoulder, 10-24 x 0.375 in.	1	D
17	939320	Block, terminal, 3-station	1 or 2	E
18	274733	Sensor, temperature, RTD	1	B
19	986305	Clip, wire-retaining	1	
20	274708	Sleeve, pivot	1	
21	186211	Kit, pivot sleeve	1	A
21	186209	Kit, pivot sleeve	1	B
21	276618	Kit, pivot sleeve	1	C
—	—	• Shell, pivot sleeve	2	F
—	—	• Screw, fillister, 6-32 x 0.500 in., with Poly-Lok	4	F
—	—	• Screw, drive, round	4	F
22	981735	Screw, fillister, 6-32 x 0.5 in., with Poly-Lok	9	
23	986322	Retaining ring, round, sect. $\frac{5}{8}$ in. ID	1	
24	940121	O-ring, Viton, 0.364 ID x 0.070 W in.	1	
25	954012	Back-up ring, single, $\frac{3}{8}$ x $\frac{1}{2}$ in.	1	
26	272404	Bearing, thrust, with grease	1	
27	986016	Retaining ring, $\frac{5}{8}$ in., external, heavy duty	1	
28	271631	Spring, conical	1	
29	983102	Washer, lock, split, 8	3	
30	981080	Screw, fillister, 8-32 x 1.25 in.	2	C
30	981081	Screw, hex, 8-32 x 1 in.	2	A
30	981082	Screw, pan, 8-32 x 1.25 in.	2	B
31	271688	Connector, swivel, $\frac{5}{16}$ in. hose	1	
32	271625	Heater, 230 VAC, 60W, 0.38 D x 1 in. L	1	A, C
32	938130	Heater, 240 VAC, 80W, 0.375 D x 1 in. L	1	B

Continued...

Item	Part	Description	Quantity	Note
33	981000	Screw, fillister, 5-40 X 0.25 in.	2	C
33	981023	Screw, fillister, 6-32 X 0.625 in.	2	A
34	804837	Thermostat, open-on-rise, 65 °C (150 °F), 10 A	1	A
34	937257	Thermostat, 190 °C (375 °F)	1	C
35	981011	Screw, fillister, 6-32 X 0.25 in.	1	
36	271615	Sleeve, bearing	1	G
37	271619	Safety, gun	1	
38	271620	Spring, wave, safety	1	
39	111688	Shell, gun, right, with slot	1	A, B
39	274383	Shell, gun, right, bulk melter	1	C
40	111676	Shell, gun, left	1	A, B
40	274384	Shell, gun, left, bulk melter	1	C
41	981800	Screw, drive, round	4	
<p>NOTE A: Used with handgun P/N 113183. B: Used with handgun P/N 121325. C: Used with handgun P/N 276577. D: Apply threadlocking adhesive P/N 900470. E: RTD gun uses qty. 1, thermostat guns use qty. 2. F: Available only as part of a kit. See item 21. G: Apply high-temperature grease, P/N 900301.</p>				
				<i>Continued...</i>

This page intentionally left blank.

AD-31 Models B and C Handgun Parts

See Figure 50.

Item	Part	Description	Quantity	Note
—	271645	Handgun, AD-31C, 190 °C (375 °F) thermostat	—	
—	111354	Handgun, AD-31C, RTD	—	
—	271644	Handgun, AD-31B, 190 °C (375 °F) thermostat	—	
1	—	Cap/plug, tapered	1	
2	940133	O-ring, Viton, 0.438 x 0.563 x 0.063 in.	1	A
3	271629	Seat	1	A, B
3	273003	Seat, carbide	1	C
4	152987	Seal, ring, seat	1	
5	271877	Cartridge, packing	1	A, B
5	271678	Cartridge, packing	1	C
6	273002	Body, gun	1	
7	984120	Nut, hex, 10-32	1	
8	271616	Linkage, trigger	1	
9	271617	Spring, compression, 0.620 x 0.455 OD x 0.039 in.	1	
10	271618	Trigger, gun	1	
11	985216	Pin, dowel, 0.250 x 1.250 in.	1	
12	981014	Screw, pan, 4-40 x 0.250 in.	2	
13	983526	Washer, lock, split	2	
14	111583	Plug with switch, 3-pin (includes protective boot)	1	B
14	274376	Plug, switch (includes protective boot)	1	A, C
15	271626	Plate, bearing	1	
16	981817	Screw, shoulder, 10-24 x 0.375 in.	1	D
17	939320	Block, terminal, 3-station	1 or 2	E
18	274733	Sensor, temperature, RTD	1	B
19	986305	Clip, wire-retaining	1	
20	274708	Sleeve, pivot	1	
21	276604	Kit, pivot sleeve	1	A
21	186210	Kit, pivot sleeve	1	B
21	276603	Kit, pivot sleeve	1	C
—	—	• Shell, pivot sleeve	2	F
—	—	• Screw, fillister, 6-32 x 0.500 in., with Poly-Lok	4	F
—	—	• Screw, drive, round	4	F
22	981735	Screw, fillister, 6-32 x 0.5 in., with Poly-Lok	9	
23	986322	Retaining ring, round, sect. $\frac{5}{8}$ in. ID	1	
24	940121	O-ring, Viton, 0.364 ID x 0.070 W in.	1	
25	954012	Back-up ring, single, $\frac{3}{8}$ x $\frac{1}{2}$ in.	1	
26	272404	Bearing, thrust, with grease	1	
27	986016	Retaining ring, $\frac{5}{8}$ in., external, heavy duty	1	
28	271631	Spring, conical	1	
29	983102	Washer, lock, split, 8	3	
30	981080	Screw, fillister, 8-32 x 1.25 in.	2	C
30	981081	Screw, hex, 8-32 x 1 in.	2	A, C
30	981082	Screw, pan, 8-32 x 1.25 in.	2	B
31	271688	Connector, swivel, $\frac{5}{16}$ in. hose	1	A, B
31	271687	Connector, swivel, $\frac{5}{8}$ in. hose	1	C
32	271625	Heater, 230 VAC, 60W, 0.38 D x 1 in. L	1	A, C

Continued...

Item	Part	Description	Quantity	Note
32	938130	Heater, 240 VAC, 80W, 0.375 D x 1 in. L	1	B
33	981000	Screw, fillister, 5-40 X 0.25 in.	2	A, C
34	937257	Thermostat, 190 °C (375 °F)	1	A, C
35	981011	Screw, fillister, 6-32 X 0.25 in.	1	
36	271615	Sleeve, bearing	1	G
37	271619	Safety, gun	1	
38	271620	Spring, wave, safety	1	
39	111688	Shell, gun, right, with slot	1	B
39	274383	Shell, gun, right, bulk melter	1	A, C
40	111676	Shell, gun, left	1	B
40	274384	Shell, gun, left, bulk melter	1	A, C
41	981800	Screw, drive, round	4	
<p>NOTE A: Used with handgun P/N 271645. B: Used with handgun P/N 111354. C: Used with handgun P/N 271644. D: Apply threadlocking adhesive P/N 900470. E: RTD gun uses qty. 1, thermostat guns use qty. 2. F: Available only as part of a kit. See item 21. G: Apply high-temperature grease, P/N 900301.</p>				
				<i>Continued...</i>

AD-31 Models B and C Handgun Parts (contd)

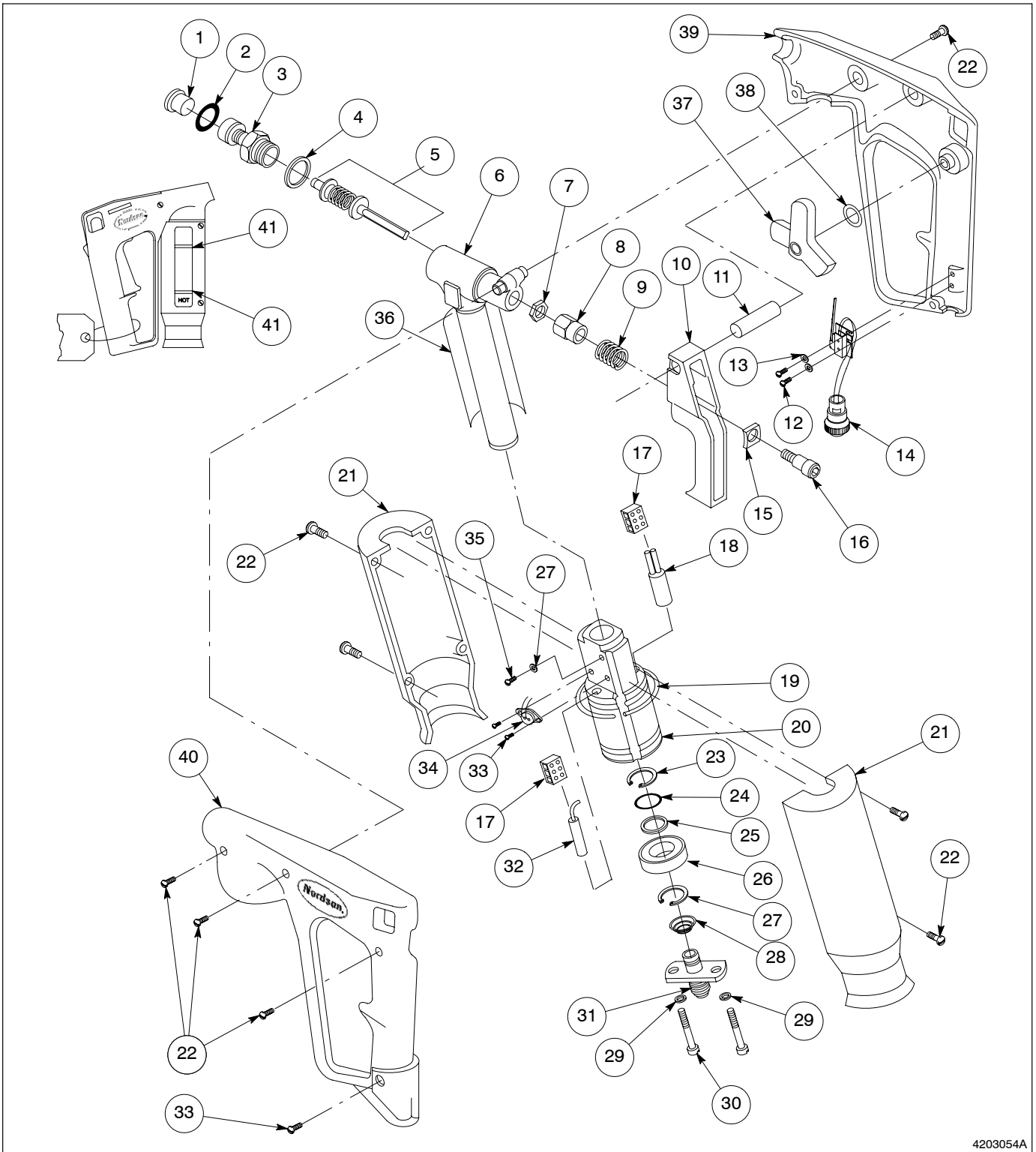

4203054A

Figure 50 AD-31 Models B and C Handgun Parts

This page intentionally left blank.

AD-31 Models A, T and TL Handgun Parts

See Figure 51.

Item	Part	Description	Quantity	Note
—	271612	Handgun, AD-31C, 190 °C (375 °F) thermostat	—	
—	274752	Handgun, AD-31C, RTD	—	
—	274765	Handgun, AD-31B, 190 °C (375 °F) thermostat	—	
1	—	Cap/plug, tapered	1	
2	940133	O-ring, Viton, 0.438 x 0.563 x 0.063 in.	1	
3	271629	Seat	1	
4	152987	Seal, ring, seat	1	
5	271877	Cartridge, packing	1	
6	273548	Body, gun	1	
7	984120	Nut, hex, 10-32	1	
8	271616	Linkage, trigger	1	
9	271617	Spring, compression, 0.620 x 0.455 OD x 0.039 in.	1	
10	271618	Trigger, gun	1	
11	985216	Pin, dowel, 0.250 x 1.250 in.	1	
12	271626	Plate, bearing	1	
13	981817	Screw, shoulder, 10-24 x 0.375 in.	1	A
14	939994	Block, terminal, 1-station	4	C, D
15	939320	Block, terminal, 3-station	1	B
16	274733	Sensor, temperature, RTD	1	C, D
17	986305	Clip, wire-retaining	1	
18	274708	Sleeve, pivot	1	
19	276602	Kit, pivot sleeve	1	B
19	276611	Kit, pivot sleeve	1	C
19	276612	Kit, pivot sleeve	1	D
—	—	• Shell, pivot sleeve	2	E
—	—	• Screw, fillister, 6-32 x 0.500 in., with Poly-Lok	4	E
—	—	• Screw, drive, round	2	E
20	981735	Screw, fillister, 6-32 x 0.5 in., with Poly-Lok	9	
21	986322	Retaining ring, round, sect. $\frac{5}{8}$ in. ID	1	
22	940101	O-ring, Viton, 0.239 ID x 0.070 W in.	1	
23	954036	Back-up ring, single, $\frac{1}{4}$ x $\frac{3}{8}$ in.	1	
24	272404	Bearing, thrust, with grease	1	
25	986016	Retaining ring, $\frac{5}{8}$ in., external, heavy duty	1	
26	271631	Spring, conical	1	
27	983102	Washer, lock, split, 8	3	
28	981080	Screw, fillister, 8-32 x 1.25 in.	2	
29	272791	Connector, swivel, $\frac{5}{16}$ in. hose	1	C, D
29	271632	Connector, swivel, $\frac{1}{4}$ in. hose	1	B
30	938143	Heater, 200 VAC, 60W, 0.375 D x 1 in. L	1	C
30	271625	Heater, 230 VAC, 60W, 0.38 D x 1 in. L	1	B
30	938130	Heater, 240 VAC, 80W, 0.375 D x 1 in. L	1	D
31	981000	Screw, fillister, 5-40 X 0.25 in.	2	B
32	937257	Thermostat, 190 °C (375 °F)	1	B
33	981011	Screw, fillister, 6-32 X 0.25 in.	1	
34	271615	Sleeve, bearing	1	F
35	271619	Safety, gun	1	

Continued...

Item	Part	Description	Quantity	Note
36	271620	Spring, wave, safety	1	
37	271621	Shell, gun, right, with insert	1	B
38	271623	Shell, gun, left	1	A, C
39	981800	Screw, drive, round	4	
NOTE A: Apply threadlocking adhesive, P/N 900470. B: Used with handgun P/N 271612. C: Used with handgun P/N 274752. D: Used with handgun P/N 274765. E: Available only as part of a kit. See item 19. F: Apply high-temperature grease, P/N 900301.				
<i>Continued...</i>				

AD-31 Models A, T and TL Handgun Parts (contd)

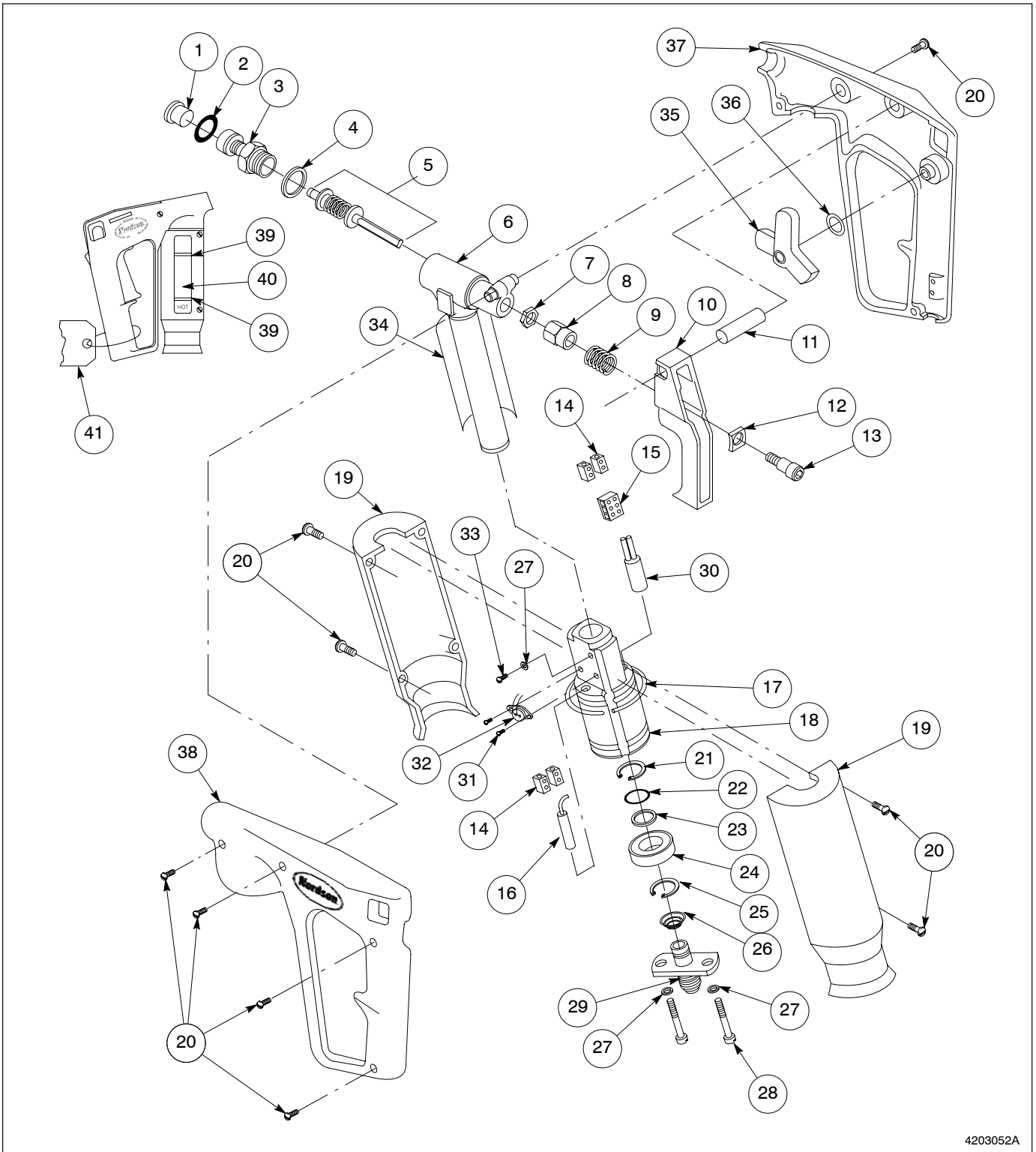

4203052A

Figure 51 AD-31 Models A, T, and TL Handgun Parts

This page intentionally left blank.

AD-31 Models D, L, E and P Handgun Parts

See Figure 52.

Item	Part	Description	Quantity	Note
—	272790	Handgun, AD-31D, 190 °C (375 °F) thermostat (for use with Series 2000 melters)	—	
—	276799	Handgun, AD-31D, 190 °C (375 °F) thermostat (for use with Model 115B melters)	—	
—	274419	Handgun, AD-31L, 190 °C (375 °F) thermostat	—	
—	276028	Handgun, AD-31E, 190 °C (375 °F) thermostat	—	
—	274940	Handgun, AD-31P, 190 °C (375 °F) thermostat	—	
1	—	Cap/plug, tapered	1	
2	940133	O-ring, Viton, 0.438 x 0.563 x 0.063 in.	1	
3	271629	Seat	1	
4	152987	Seal, ring, seat	1	
5	271877	Cartridge, packing	1	
6	273548	Body, gun	1	
7	984120	Nut, hex, 10-32	1	
8	271616	Linkage, trigger	1	
9	271617	Spring, compression, 0.620 x 0.455 OD x 0.039 in.	1	
10	271618	Trigger, gun	1	
11	985216	Pin, dowel, 0.250 x 1.250 in.	1	
12	271626	Plate, bearing	1	
13	981817	Screw, shoulder, 10-24 x 0.375 in.	1	
14	939320	Block, terminal, 3-station	1	
15	271625	Heater, 230 VAC, 60W, 0.38 D x 1 in. L	1	A, B
15	274418	Heater, 200 VAC, with form leads	1	C
15	274094	Heater, 120 VAC, 65W, 0.38 D x 1 in. L	1	D
15	274911	Heater, 100 VAC, 65W, 0.38 D x 1 in. L	1	E
16	986305	Clip, wire-retaining	1	
17	274708	Sleeve, pivot	1	
18	276607	Kit, pivot sleeve	1	A
18	276803	Kit, pivot sleeve	1	B
18	276610	Kit, pivot sleeve	1	C
18	276614	Kit, pivot sleeve	1	D
18	276613	Kit, pivot sleeve	1	E
—	—	• Shell, pivot sleeve	2	F
—	—	• Screw, fillister, 6-32 x 0.500 in., with Poly-Lok	4	F
—	—	• Screw, drive, round	2	F
19	981735	Screw, fillister, 6-32 x 0.5 in., with Poly-Lok	9	
20	986322	Retaining ring, round, sect. $\frac{5}{8}$ in. ID	1	
21	940101	O-ring, Viton, 0.239 ID x 0.070 W in.	1	
22	954036	Back-up ring, single, $\frac{1}{4}$ x $\frac{3}{8}$ in.	1	
23	272404	Bearing, thrust, with grease	1	
24	986016	Retaining ring, $\frac{5}{8}$ in., external, heavy duty	1	
25	271631	Spring, conical	1	
26	983102	Washer, lock, split, 8	3	
27	981080	Screw, fillister, 8-32 x 1.25 in.	2	
28	272791	Connector, swivel, $\frac{5}{16}$ in. hose	1	A, B, C
28	274084	Connector, swivel, $\frac{5}{8}$ in. hose	1	D, E

Continued...

Item	Part	Description	Quantity	Note
29	981000	Screw, fillister, 5-40 X 0.25 in.	2	
30	937257	Thermostat, 190 °C (375 °F)	1	
31	981011	Screw, fillister, 6-32 X 0.25 in.	1	
32	271615	Sleeve, bearing	1	G
33	271619	Safety, gun	1	
34	271620	Spring, wave, safety	1	
35	271621	Shell, gun, right, with insert	1	
36	271623	Shell, gun, left	1	
37	981800	Screw, drive, round	4	
<p>NOTE A: Used with handgun P/N 272790. B: Used with handgun P/N 276799. C: Used with handgun P/N 274419. D: Used with handgun P/N 276028. E: Used with handgun P/N 274940. F: Available only as part of a kit. See item 18. G: Apply high-temperature grease, P/N 900301.</p>				
				<i>Continued...</i>

AD-31 Models D, L, E and P Handgun Parts (contd)

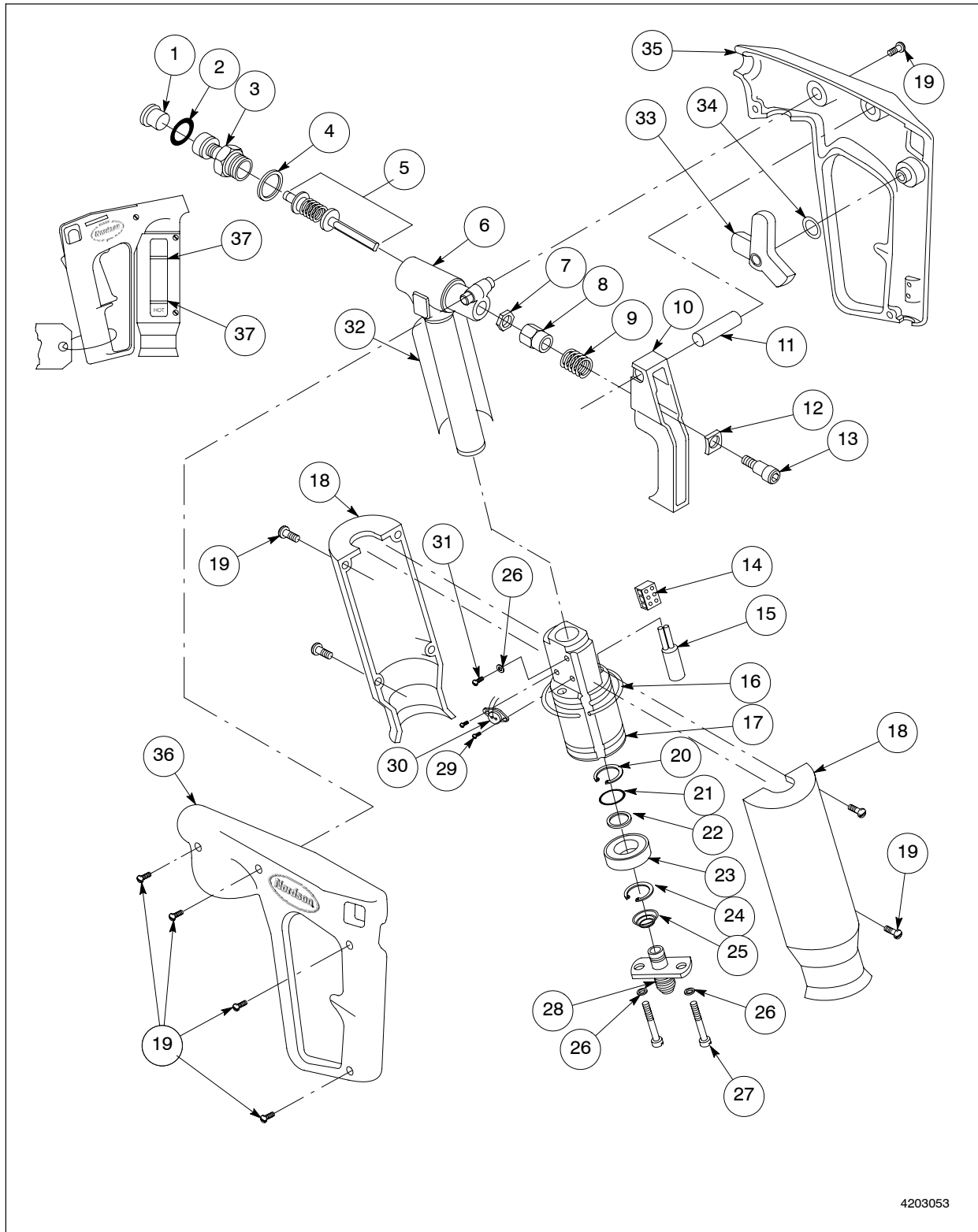

4203053

Figure 52 AD-31 Models D, L, E, and P Parts

This page intentionally left blank.

L4 Handgun Parts

See Figure 53. Refer to *Handgun Selection in Description* for the top-level part numbers of L4 handguns.

Item	Part	Description	Quantity	Note
1	—	Cap/plug, tapered	1	
2	940133	O-ring, Viton, 0.438 x 0.563 x 0.063 in.	1	
3	271629	Seat	1	
4	152987	Seal, ring, seat	1	
5	271877	Cartridge, packing	1	
6	273548	Body, gun	1	
6	273002	Body, gun	1	A, B, C, D, E, F, G, H
7	984120	Nut, hex, 10-32	1	J, K, L, M
8	271616	Linkage, trigger	1	
9	271617	Spring, compression, 0.62 x 0.455 OD x 0.039 in.	1	
10	182046	Trigger, gun	1	
11	985216	Pin, dowel, 0.250 x 1.25 in.	1	
12	981014	Screw, pan, 4-40 x .25 in.	2	J, K, L, M
13	983526	Washer, lock, split, 4	2	J, K, L, M
14	111583	Plug, with switch, 3-pin, keyed (includes boot)	1	J, K, L, M
15	271626	Plate, bearing	1	
16	981817	Screw, shoulder, 10-24 x 0.375 in.	1	
NS	939994	Block, terminal, 2-station	4	B, C, D, E, F, J, L
17	939320	Block, terminal, 3-station	1	A, G, H, K, M
18A	224914	Heater, 120 VAC, 80W, 1 in. L	1	B, C, J
18A	224911	Heater, 240 VAC, 80W, 0.38 D x 1 in. L	1	D, E, F, L
18B	1020552	Service kit, heater, 115 VAC, with thermostat	1	A, K
18B	1020553	Service kit, heater, 230 VAC, with thermostat	1	G, H, M
19	986305	Clip, wire-retaining	1	
20	1020559	Sleeve, pivot	1	A, G, H, K, M
20	274708	Sleeve, pivot	1	B, C, D, E, F, J, L
21	271627	Shell, pivot sleeve	2	
22	981735	Screw, fillister, 6-32 x 0.5 in., with Poly-Lok	9	
23	986322	Retaining ring, round, sect. $\frac{5}{8}$ in. ID	1	
24	940121	O-ring, Viton, 0.364 ID x 0.070 W in.	1	J, K, L, M
25	954012	Back-up ring, single, $\frac{3}{8}$ x $\frac{1}{2}$ in.	1	J, K, L, M
26	272404	Bearing, thrust, with grease	1	
27	986016	Retaining ring, $\frac{5}{8}$ in., external, heavy duty	1	
28	271631	Spring, conical	1	
29	983111	Washer, lock, split, 8	3	
30	981082	Screw, pan, 8-32 x 1.25 in.	2	
31	272791	Connector, swivel, $\frac{5}{16}$ in. hose	1	A, B, C, D, E, F, G, H
31	271688	Connector, swivel, $\frac{5}{16}$ in. hose	1	J, K, L, M
32	1028826	Kit, RTD, 100 ohms	1	A, G, H, K, M
33	981000	Screw, fillister, 5-40 X 0.25 in.	2	
34	937254	Thermostat, 149 °C (300 °F)	1	B
34	937256	Thermostat, 177 °C (350 °F)	1	D

Continued...

Item	Part	Description	Quantity	Note
34	937257	Thermostat, 190 °C (375 °F)	1	C, E, J, L
34	937259	Thermostat, 218 °C (425 °F)		F
35	981011	Screw, fillister, 6-32 X 0.25 in.	1	
36	271615	Sleeve, bearing	1	
37	182045	Trigger, safety, gun	1	
38	271620	Spring, wave, safety	1	
39	182050	Shell, gun, right	1	A, B, C, D, E, F, G, H
39	182049	Shell, gun, right	1	J, K, L, M
40	174192	Shell, gun, left	1	A, B, C, D, E, F, G, H
40	182048	Shell, gun, left	1	J, K, L, M
41	981800	Screw, drive, round	4	
<p>NOTE A: Used with handgun P/N 1020528. B: Used with handgun P/N 1020529. C: Used with handgun P/N 182032. D: Used with handgun P/N 1020530. E: Used with handgun P/N 182033. F: Used with handgun P/N 1020533. G: Used with handgun P/N 1020534. H: Used with handgun P/N 1020535. I: Letter not used. J: Used with handgun P/N 1020536. K: Used with handgun P/N 182034. L: Used with handgun P/N 1020538. M: Used with handgun P/N 182035.</p>				
<i>Continued...</i>				

L4 Handgun Parts (contd)

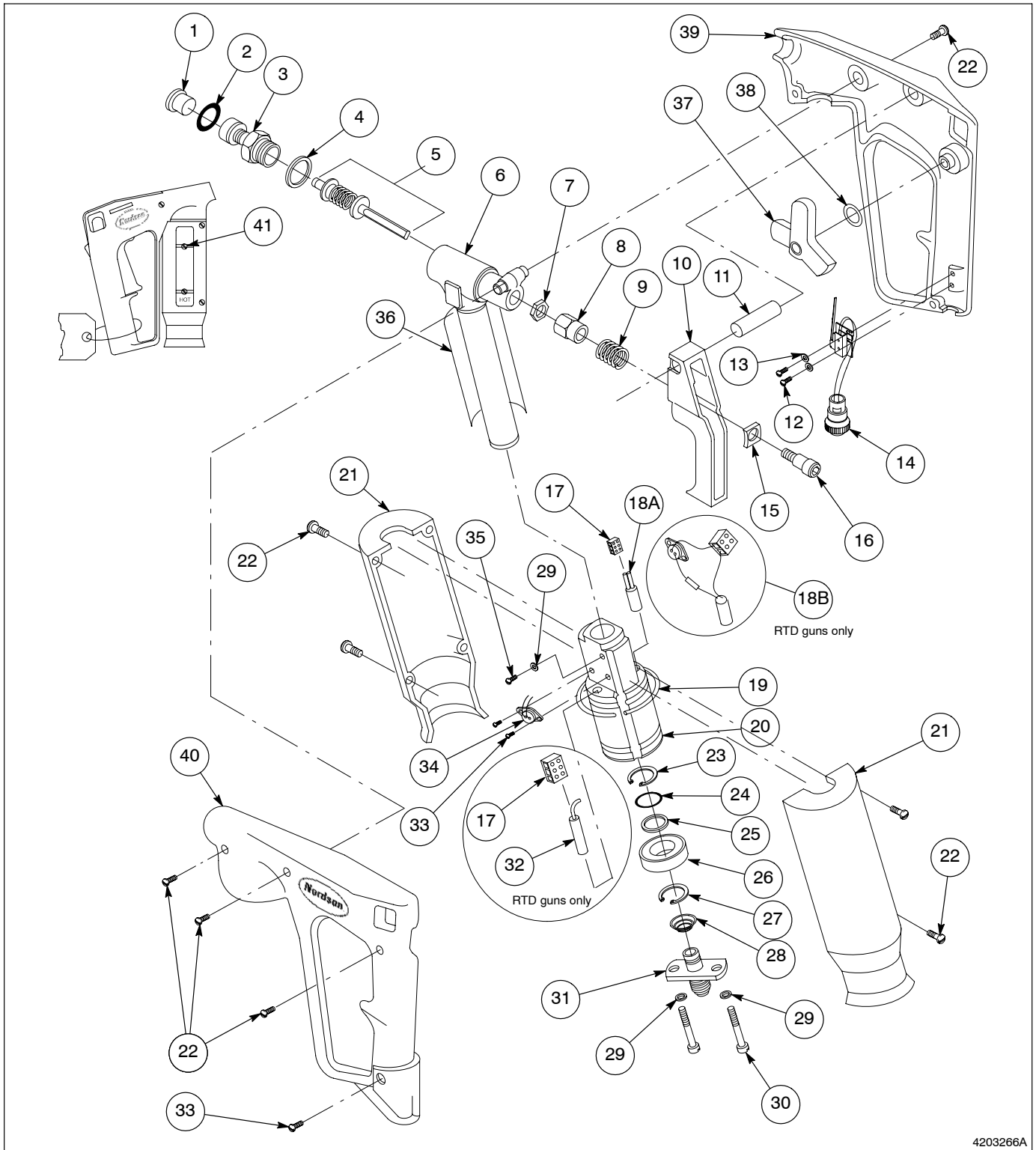

Figure 53 L4 Handgun Parts

Recommended Spare Parts

AD-31 Handgun Spare Parts List

Part	Description	Quantity	Note
900301	Grease, lubricating, silicone, 150 g (5.3 oz)	1	
271678	Cartridge, packing	1	A, B
271877	Cartridge, packing	1	C, D, E
271615	Sleeve, bearing	1	L
274733	Sensor, temperature, RTD	1	A, B, C, D, E, F
937257	Thermostat, 90 °C (375 °F)	1	
938130	Heater, 0.375 in. diameter, 1.00 in. length, 80 W, 240 VAC	1	J
271625	Heater, 0.38 in. diameter, 1.00 in. length, 60 W, 230 VAC	1	K
274094	Heater, 0.38 in. diameter, 1.00 in. length, 65 W, 120 VAC	1	H
274418	Heater, 200 VAC, with form leads	1	G
938143	Heater, 0.38 in. diameter, 1.00 in. length, 60 W, 200 VAC	1	F
274911	Heater, 0.38 in. diameter, 1.00 in. length, 65 W, 100 VAC	1	I
939320	Block, terminal, 3-station	2	A, B, C, D, G, H, I, J
939994	Block, terminal, 1-station	4	E, F
272404	Bearing, thrust, with grease	1	
940101	O-Ring, Viton, 0.250 x 0.375 x 0.063 in.	1	D, E, F, G, H, I, J
954036	Back-up ring, single, $\frac{1}{4} \times \frac{3}{8}$ in.	1	D, E, F, G, H, I, J
940121	O-Ring, Viton, 0.364 ID x 0.070 W in.	1	A, B, C
954012	Back-up ring, single, $\frac{3}{8} \times \frac{1}{2}$ in.	1	A, B, C

NOTE A: Used with AD-31 handgun model K (parts 113183, 121325, and 276577).

B: Used with AD-31 handgun model B (part 271645).

C: Used with AD-31 handgun model C (parts 271645 and 111354).

D: Used with AD-31 handgun model A (part 271612).

E: Used with AD-31 handgun model T (part 274765).

F: Used with AD-31 handgun model TL (part 274752).

G: Used with AD-31 handgun model D (parts 272790 and 276799).

H: Used with AD-31 handgun model L (part 274419).

I: Used with AD-31 handgun model E (part 276028).

J: Used with AD-31 handgun model P (part 274940).

K: Apply a high-temperature grease P/N 900301.

L4 Handgun Spare Parts List

Part	Description	Quantity	Note
900301	Grease, lubricating, silicone, 150 g (5.3 oz)	1	
271877	Cartridge, packing	1	
271615	Sleeve, bearing	1	N
182043	Sensor, temperature, platinum, 100 ohms (RTD)	1	A, G, H, K, M
937254	Thermostat, 149 °C (300 °F)	1	B
937256	Thermostat, 177 °C (350 °F)	1	D
937257	Thermostat, 190 °C (375 °F)	1	C, E, J, L
937259	Thermostat, 218 °C (425 °F)	1	F
224914	Heater, 120 VAC, 80 W, 1.00 in. length	1	B, C, J
224911	Heater, 240 VAC, 80 W, 1.00 in. length	1	D, E, F, L
1020552	Service kit, heater, 115 VAC, thermostat assembly	1	A, K
1020553	Service kit, heater, 230 VAC, thermostat assembly	1	G, H, M
939320	Block, terminal, 3-station	2	B, C, D, E, F, J, L
939586	Block, terminal, 2-station	4	A, G, H, K, M
272404	Bearing, thrust, with grease	1	
940133	O-Ring, Viton, 0.438 x 0.563 x 0.063 in.	1	
940121	O-Ring, Viton, 0.364 ID x 0.070 W in.	1	J, K, L, M
954012	Back-up ring, single, $\frac{3}{8}$ x $\frac{1}{2}$ in.	1	J, K, L, M
<p>NOTE A: Used with L4 handgun part 1020528. B: Used with L4 handgun part 1020529. C: Used with L4 handgun part 182032. D: Used with L4 handgun part 1020530. E: Used with L4 handgun part 182033. F: Used with L4 handgun part 1020533. G: Used with L4 handgun part 1020534. H: Used with L4 handgun part 1020535. I: Letter not used. J: Used with L4 handgun part 1020536. K: Used with L4 handgun part 182034. L: Used with L4 handgun part 1020538. M: Used with L4 handgun part 182035. N: Apply a high-temperature grease P/N900301.</p>			
			<i>Continued...</i>

Extrusion Nozzles

Series AD-31 and L4 handguns use a variety of nozzles. The orifice diameter and the length of the nozzle (engagement) affect adhesive flow. Adhesive flows more quickly as the orifice diameter increases. Adhesive flow decreases as engagement is lengthened. Contact a Nordson representative for assistance in nozzle selection.

Male-Threaded Standard Engagement Nozzles, Small Ball-and-Seat

These nozzles may be used with AD-31 handgun models A, C, D, E, L, P, T, and TL and with all L4 handguns.

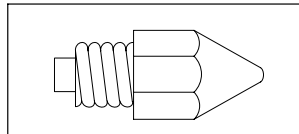

Part	Description
238252	Nozzle, 0.020 in. dia.
238253	Nozzle, 0.030 in. dia.
238254	Nozzle, 0.040 in. dia.
238256	Nozzle, 0.060 in. dia.
238259	Nozzle, 0.090 in. dia.
238260	Nozzle, 0.093 in. dia.

Male-Threaded Extended Engagement Nozzles, Small Ball-and-Seat

These nozzles may be used with AD-31 handgun models A, C, D, E, L, P, T, and TL and with all L4 handguns.

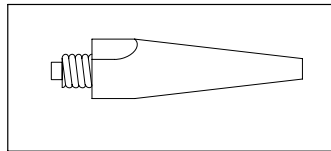

Part	Description
274968	Nozzle, 0.042 in. dia.
274969	Nozzle, 0.061 in. dia.
274970	Nozzle, 0.090 in. dia.
274971	Nozzle, 0.130 in. dia.

Male-Threaded Extended Engagement Nozzles, Large Ball-and-Seat

These nozzles may be used with AD-31 handgun models B and K.

Part	Description
804387	Nozzle, 0.062 in. dia.
271683	Nozzle, 0.093 in. dia.
271684	Nozzle, 0.125 in. dia.
271685	Nozzle, 0.156 in. dia.

Accessories

Part	Description
270755	Type R fluid, 1 gal.
900301	Grease, lubricating, silicone, 150 g (5.3 oz)
900470	Threadlocking adhesive
901915	Nozzle cleaning kit